

# Model T17

## *Ultrasonic Flow Transducer*

### Installation Guide





GE  
Measurement & Control

# Model T17

*Ultrasonic Flow Transducer*

## Installation Guide

916-128 Rev. C  
August 2015



[www.gemeasurement.com](http://www.gemeasurement.com)

©2015 General Electric Company. All rights reserved.  
Technical content subject to change without notice.

[no content intended for this page]

**Chapter 1. Introduction**

1.1 Overview.....1  
 1.2 Transducer Construction.....1  
 1.3 Certification and Safety Statements.....2

**Chapter 2. Installing Pipe Nozzles**

2.1 Introduction.....3  
 2.2 Diametrical Path Nozzle Installation.....4  
     2.2.1 Identifying and Checking the Nozzle Installation Kit Components, Diametrical.....5  
     2.2.2 Selecting and Marking the First Nozzle Location, Diametrical.....6  
     2.2.3 Determining and Marking the Second Nozzle Location, Diametrical.....8  
     2.2.4 Installing the First Welding Boss, Diametrical.....11  
     2.2.5 Installing the First Nozzle, Diametrical.....13  
     2.2.6 Installing the Second Welding Boss and Nozzle, Diametrical.....15  
     2.2.7 Hot Tapping the Pipe.....16  
     2.2.8 Cold Tapping the Pipe.....16  
 2.3 Non-Diametrical Mid Radius Path Nozzle Installation.....16  
     2.3.1 Identifying and Checking the Nozzle Installation Kit Components, Non-Diametrical, Mid-Radius...17  
     2.3.2 Selecting and Marking the First Nozzle Location, Non-Diametrical, Mid-Radius.....18  
     2.3.3 Determining and Marking the Second Nozzle Location, Non-Diametrical, Mid-Radius.....22  
     2.3.4 Installing the First Welding Boss, Non-Diametrical, Mid-Radius.....26  
     2.3.5 Installing the First Nozzle, Non-Diametrical Mid Radius.....29  
     2.3.6 Installing the Second Welding Boss and Nozzle, Non-Diametrical Mid Radius.....31  
     2.3.7 Hot Tapping the Pipe.....32  
     2.3.8 Cold Tapping the Pipe.....32

**Chapter 3. Installing an Isolation Valve**

3.1 Diametrical or Non-Diametrical Nozzle, Valve Installation.....33  
     3.1.1 For 3 inch Flanges.....33

**Chapter 4. Inserting T17 Transducers into the Pipe**

4.1 Introduction.....35  
 4.2 Inserting Transducers Using the Insertion Mechanism.....35  
     4.2.1 Preparing for Installation.....35  
     4.2.2 Mounting the Insertion Mechanism.....36  
     4.2.3 Aligning the Downstream Transducer for Extended Range Installations.....43  
 4.3 Connecting an XAMP.....47

**Chapter 5. Maintaining the T17 Transducers**

5.1 Removing Transducers.....53  
     5.1.1 Using the Insertion Mechanism.....53

**Chapter 6. Specifications**

6.1 T17 Transducer Physical Specifications.....57  
 6.2 T17 Transducer Certifications.....57

[no content intended for this page

---

## Information Paragraphs

**Note:** *These paragraphs provide information that provides a deeper understanding of the situation, but is not essential to the proper completion of the instructions.*

**IMPORTANT:** *These paragraphs provide information that emphasizes instructions that are essential to proper setup of the equipment. Failure to follow these instructions carefully may cause unreliable performance.*



**CAUTION!** This symbol indicates a risk of potential minor personal injury and/or severe damage to the equipment, unless these instructions are followed carefully.



**WARNING!** This symbol indicates a risk of potential serious personal injury, unless these instructions are followed carefully.

## Safety Issues



**WARNING!** It is the responsibility of the user to make sure all local, county, state and national codes, regulations, rules and laws related to safety and safe operating conditions are met for each installation.



**WARNING!** For installations in potentially hazardous areas, be sure to read the *Certification and Safety Statements* document at the end of this manual before beginning the installation.

## Auxiliary Equipment

### Local Safety Standards

The user must make sure that he operates all auxiliary equipment in accordance with local codes, standards, regulations, or laws applicable to safety.

### Working Area



**WARNING!** Auxiliary equipment may have both manual and automatic modes of operation. As equipment can move suddenly and without warning, do not enter the work cell of this equipment during automatic operation, and do not enter the work envelope of this equipment during manual operation. If you do, serious injury can result.



**WARNING!** Make sure that power to the auxiliary equipment is turned OFF and locked out before you perform maintenance procedures on the equipment.

## Qualification of Personnel

Make sure that all personnel have manufacturer-approved training applicable to the auxiliary equipment.

## Personal Safety Equipment

Make sure that operators and maintenance personnel have all safety equipment applicable to the auxiliary equipment. Examples include safety glasses, protective headgear, safety shoes, etc.

## Unauthorized Operation

Make sure that unauthorized personnel cannot gain access to the operation of the equipment.

## Environmental Compliance

### Waste Electrical and Electronic Equipment (WEEE) Directive

GE Measurement & Control is an active participant in Europe's *Waste Electrical and Electronic Equipment (WEEE)* take-back initiative, directive 2012/19/EU.

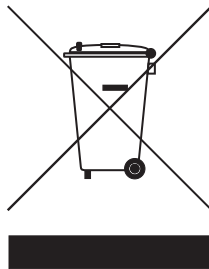

The equipment that you bought has required the extraction and use of natural resources for its production. It may contain hazardous substances that could impact health and the environment.

In order to avoid the dissemination of those substances in our environment and to diminish the pressure on the natural resources, we encourage you to use the appropriate take-back systems. Those systems will reuse or recycle most of the materials of your end life equipment in a sound way.

The crossed-out wheeled bin symbol invites you to use those systems.

If you need more information on the collection, reuse and recycling systems, please contact your local or regional waste administration.

Visit <https://www.gemeasurement.com/environmental-health-safety-ehs> for take-back instructions and more information about this initiative.



# Chapter 1. Introduction

## 1.1 Overview

The *T17 ultrasonic flow transducer* is used exclusively with the GE line of ultrasonic flowmeters. These transducers measure the flow rate of sonically-conductive gases through pipes having diameters between 12 in. (305 mm) and 120 in. (3000 mm). This manual provides details on the following topics:

- Transducer construction
- Nozzle installation
- Transducer installation
- Maintenance
- Specifications

**Note:** *For installation on pipes ranging from 4 to 12 in. (100 to 300 mm), or for using the BIAS 90° configuration, please see the GE 916-117 Installation Guide.*

## 1.2 Transducer Construction

Each T17 transducer assembly (see *Figure 1* below) consists of the following components:

- A fully sealed, welded, all metal body made from grade 2 titanium as standard
- A transducer head that consists of piezoelectric elements wired to the BNC connector
- A BNC style connector for use in connecting the transducer to the flowmeter

The T17 transducer is available in standard lengths of 33 in. (840 mm) to 60 in. (1500 mm) and with either a 180° or 174° angled head.

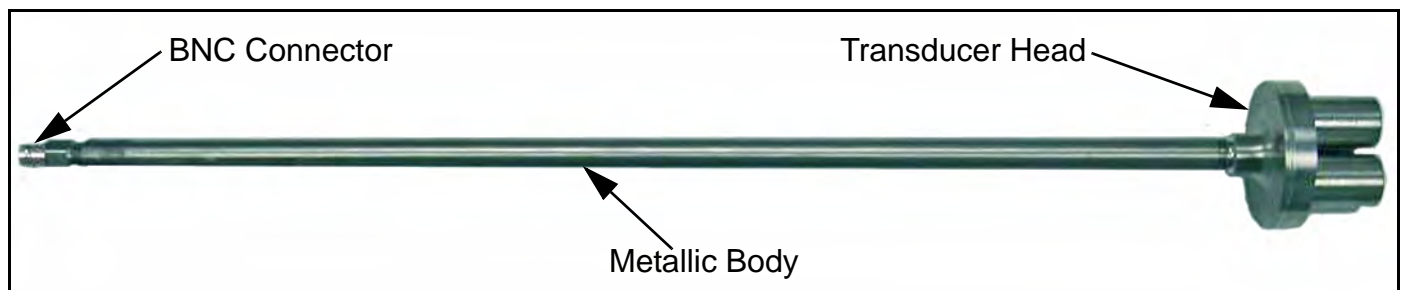

Figure 1: General T17 Transducer (180° Head)

### 1.3 Certification and Safety Statements

To maintain DEKRA certification, the transducer is provided with a ATEX and IECEx certified compression fitting and/or adapter of either thread M25 X 1.5 (material: brass) or ¾” NPT (material: 316 SS), both with tube size of 0.50” O.D. For example: Tyco part number 496SSGL34Ex ATEX certified under BASEEFA 08ATEX0327X and IECEx BAS08.0107X, Peppers adapter part number ARB/NP/075NPT/M20 ATEX certified under SIRA09ATEX1322X or SIRA09ATEX4323X and IECEx SIR09.0121X and reducer Capri part number 740724 ATEX certified under LCIO8ATEX6085X and IECEx LC018.0035X or equivalent parts. ATEX/IECEx certified enclosure, Type Ex d IIC. For example: International Metal Engineering PTE Limited (IME) Type 8080, 8075, 8066 or 7080 certified under SIRA 07ATEX1331U and IECEx SIR 07.0111U or equivalent that complies with EN 60079-0:2012/IEC 60079-0:2011 and EN 60079-1:2007/IEC 60079-1:2007. For example: Cortem SL-26.1N certified under CESI 03ATEX032U or equivalent. A certified metric-to-NPT adapter (material: brass) may be used in addition to the compression fitting in applicable configurations. Both fitting and adapter to comply with EN 60079-0:2012/ IEC 60079-0:2011 and EN 60079-1:2007/ IEC 60079-1:2007 for Ex d IIC. For electrical connection, the transducer must be mounted into a certified metal enclosure with type of protection flameproof enclosure “D”, complying with EN 60079-1:2007 and IEC 60079-1:2007 Ex d IIC. Measures must be taken to ensure a good electrical contact and to prevent the threads from self-loosening. The compression fitting is suitable for temperatures –60°C to 250°C.

## Chapter 2. Installing Pipe Nozzles

### 2.1 Introduction

Before the T17 transducers can be installed into the pipe, you will need to install pipe nozzles. Nozzles may be installed as part of a fabricated spoolpiece, or by using the hot or cold process with a *GE Nozzle Installation Kit*.

**IMPORTANT:** *This procedure only applies if you are using a Nozzle Installation Kit. If you are tapping the pipe without using a Nozzle Installation Kit, refer to the supplied drawings in your shipment. This procedure is written and illustrated for installations on horizontal pipes. However, the procedure is the same for vertical pipe installations.*

This section describes how to install nozzles in the different available configurations:

- Standard flow range operation of 0.1 to 328 f/s (0.03 to 100 m/s):  
*This configuration uses two 180° head T17 transducers.*
- Extended range operation of 0.1 to 394 f/s (0.03 to 120 m/s):  
*This configuration uses one 180° head T17 transducer and one 174° head T17 transducer.*

Either of these arrangements may be used on one of two path configurations:

- A diametrical path configuration (the signal path forms a line through the pipe diameter (see *Figure 2* below).
- A non-diametrical path configuration (the signal path forms a line offset from the diameter (see *Figure 3* below).

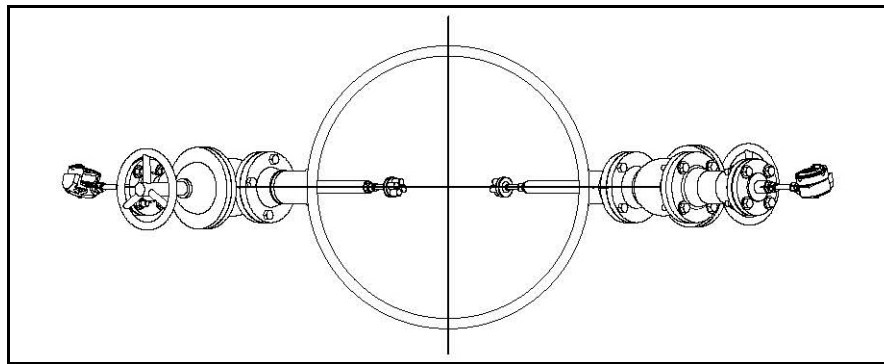

Figure 2: Diametrical Path Configuration

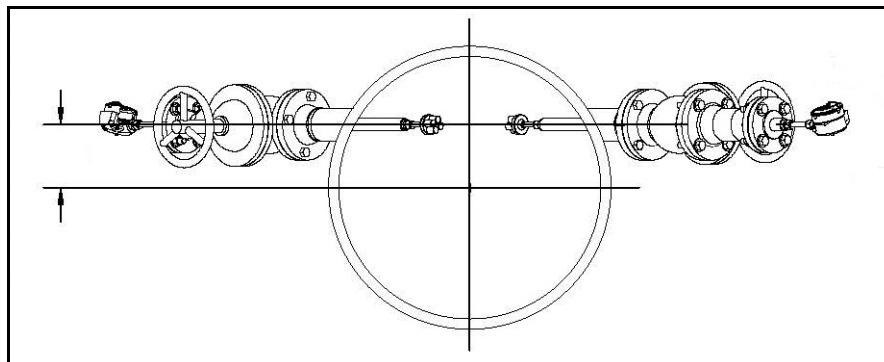

Figure 3: Non-Diametrical Path Configuration

## 2.2 Diametrical Path Nozzle Installation

This procedure includes the following instructions:

- Identifying and checking the nozzle installation kit components
- Selecting and marking the first nozzle location
- Determining and marking the second nozzle location
- Installing the first welding boss
- Installing the first nozzle
- Installing the second welding boss and nozzle
- Hot tapping the pipe

### 2.2.1 Identifying and Checking the Nozzle Installation Kit Components, Diametrical

The nozzle kit consists of various components which you must identify and check as described in the following sub-sections.

The *Nozzle Installation Kit* contains the materials listed below. Use *Figure 4* below to help identify each component.

• 2 Nozzles (if purchased)	• 2 Welding bosses	• 1 Jig	• 1 Threaded rod (1 in. diameter), washer and nut
----------------------------	--------------------	---------	---

**IMPORTANT:** *You will need to supply eight 5/8" studs with two nuts each (for 3", 150# flanges), or 3/4" studs with two nuts each (for 3", 300# flanges).*

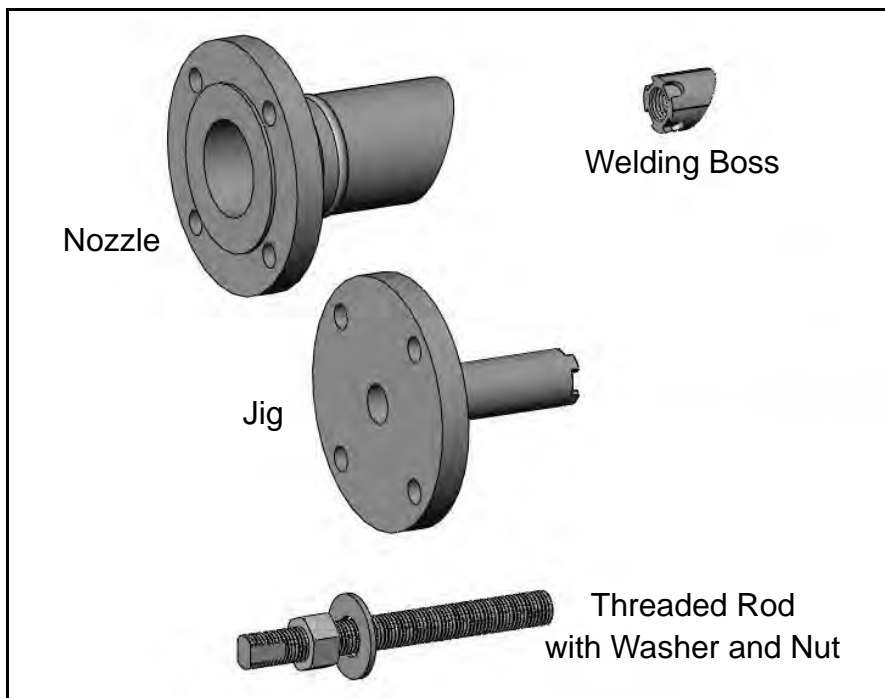
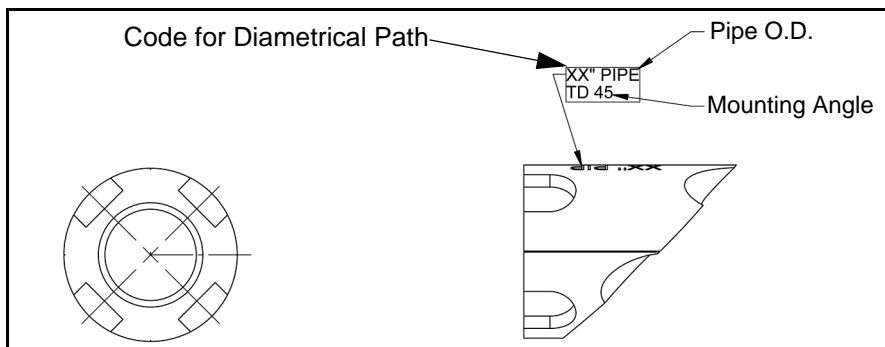

Figure 4: Components in Nozzle Installation Kit

Check the marking on the welding boss. The pipe OD and the mounting angle are engraved on the boss as shown below.



## 2.2.2 Selecting and Marking the First Nozzle Location, Diametrical



**CAUTION!** Correct nozzle alignment is critical to the successful operation of the flowmeter. Therefore, all marking, positioning and welding operations must be carried out with the utmost attention to accuracy. Unless otherwise stated, dimensional positioning of the nozzles must be held to a tolerance of  $\pm 1/16$  in. ( $\pm 1.6$  mm) relative to each other and with respect to the pipe centerline. the angular tolerance must be held to  $\pm 1^\circ$ .

All hole cutting in process piping must be performed using hot tapping equipment.

1. For optimum performance, you should select a location that has at least 20 pipe diameters of straight, undisturbed flow upstream and 10 pipe diameters of straight, undisturbed flow downstream from the measurement point. Undisturbed flow means avoiding sources of turbulence such as valves, flanges, elbows; avoiding swirl; and avoiding disturbed flow profiles.

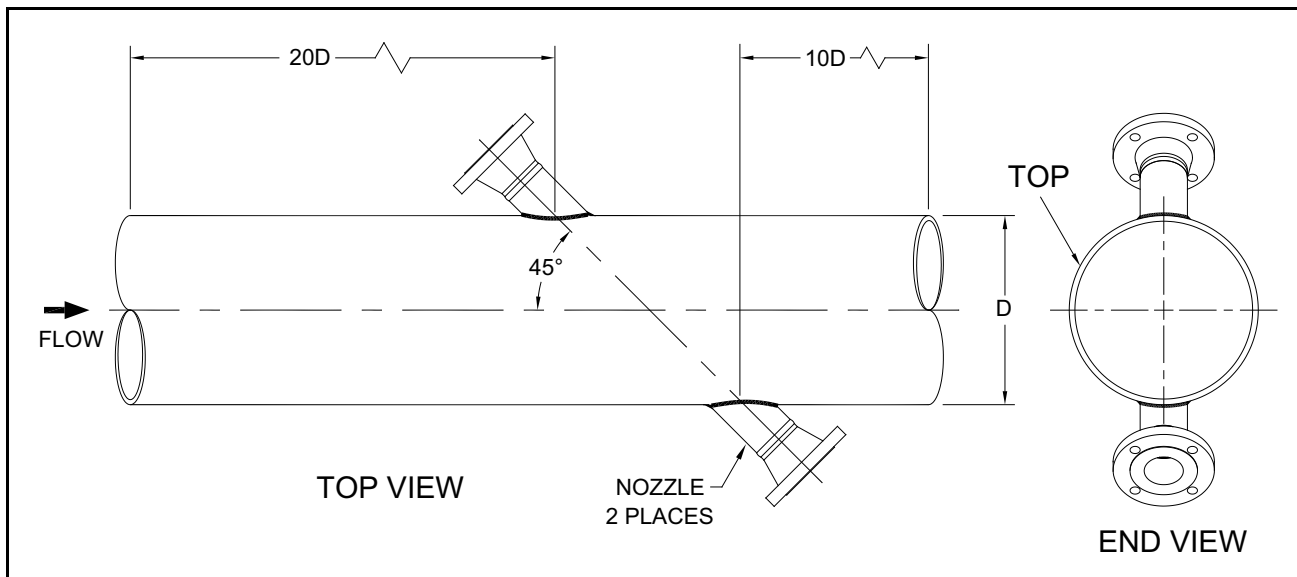

2. We recommend that you install the nozzles on a diameter as near as possible to the horizontal plane (i.e., 3 o'clock and 9 o'clock positions) for horizontal pipe.

**Note:** *If you cannot find a proper location, please consult with GE Flow Application engineering.*

### 2.2.2 Selecting and Marking the First Nozzle Location, Diametrical (cont.)

3. At the 3 o'clock position, center punch the pipe to mark the position for the center of the first nozzle.

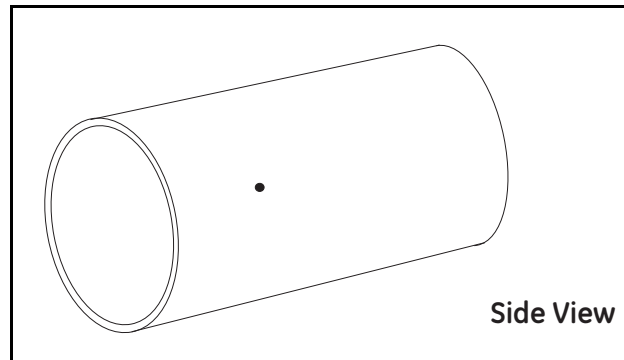

4. Spray this area with a marking dye product. Using a metal edge, scribe 6" long vertical and a horizontal lines that intersect at the center punch mark.

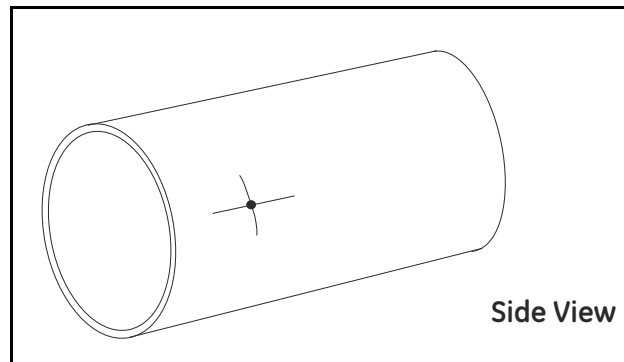

### 2.2.3 Determining and Marking the Second Nozzle Location, Diametrical

1. The position for the second nozzle is typically a distance equal to one pipe outside diameter along the pipe and located on the opposite side of the pipe (i.e., 180° around). Spray this area with a marking dye product. (For installation other than 45°, the distance is equal to the OD times the tangent of the installation angle.)
2. Due to the possible variation in outside diameter of the pipe, measure the outside diameter of the pipe at four locations between the nozzle centers. Calculate the average outside diameter based on these measurements.

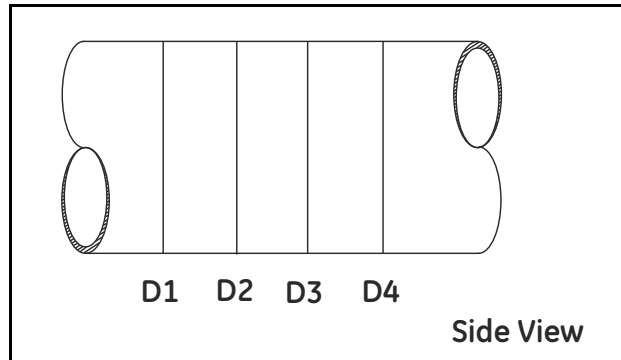

3. Using a roll of polyester film (or equivalent), cut a strip of film with the following width and length:

**IMPORTANT:** *Ensure that the sides of the film are cut parallel to each other.*

- Width: equal to the average outside diameter calculated in Step 2 above.
- Length: equal to 4 times the outside diameter of the pipe.

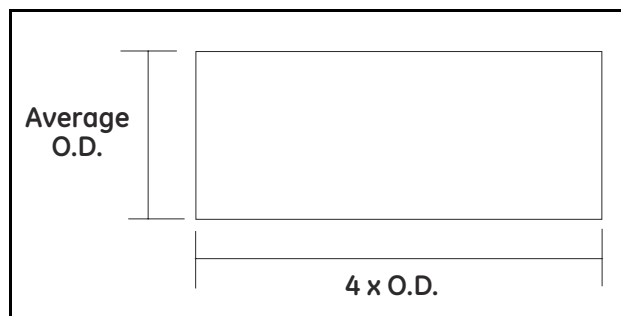



### 2.2.3 Determining and Marking the Second Nozzle Location, Diametrical (cont.)

4. Wrap the strip of film around the pipe with one edge running along the vertical scribe line at the first nozzle location. Make sure the strip overlaps squarely around the pipe and mark the overlap position of the strip. This equals the circumference of the pipe.

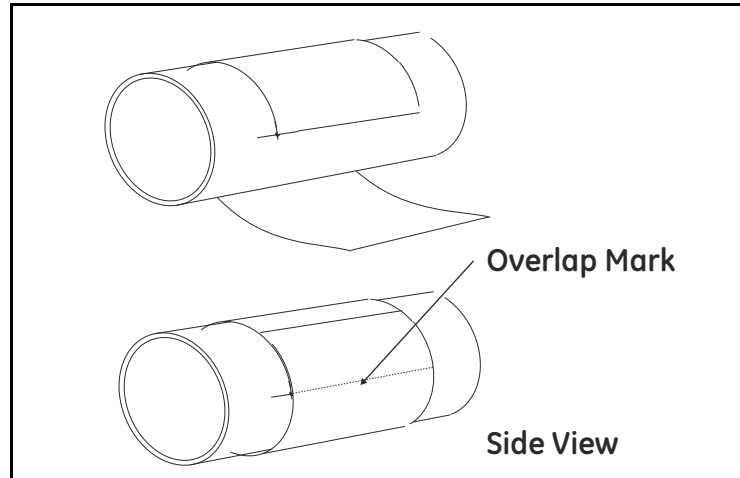

5. Remove the strip of film and fold it as shown below to determine the position which is diametrically opposite the overlap position when the film is reapplied to the pipe.

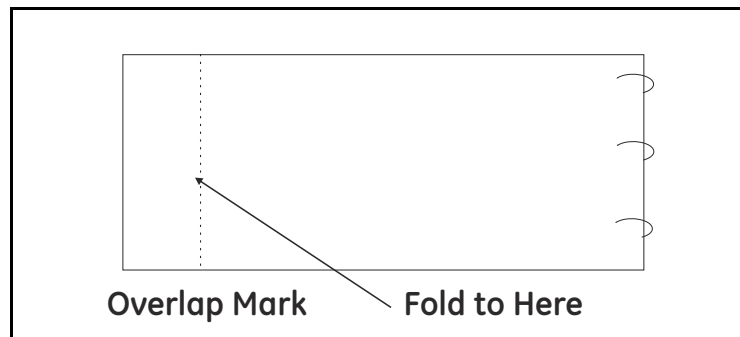

6. Mark the outside of the fold for reference.

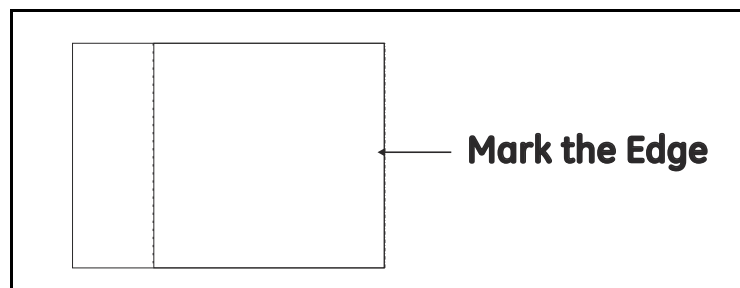

### 2.2.3 Determining and Marking the Second Nozzle Location, Diametrical (cont.)

7. Place the strip of film on the pipe again. This time, line up the overlap mark with the horizontal and vertical scribe lines. Again, make sure you wrap the strip of film squarely around the pipe.

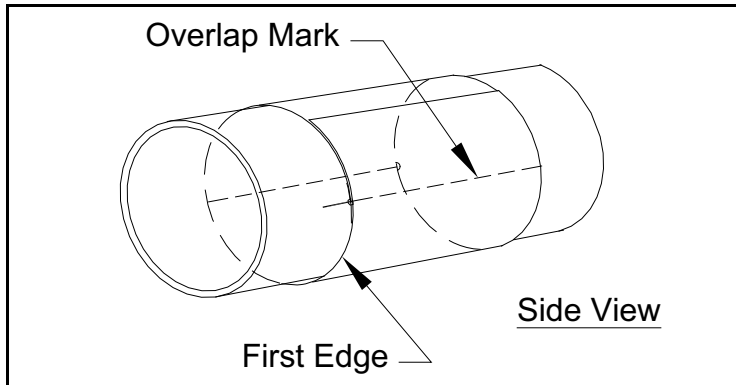

8. The new position of the center of the second nozzle is now identified as the intersection of the fold line and the second edge of the strip of film. Center punch this location prior to removing the strip of film.

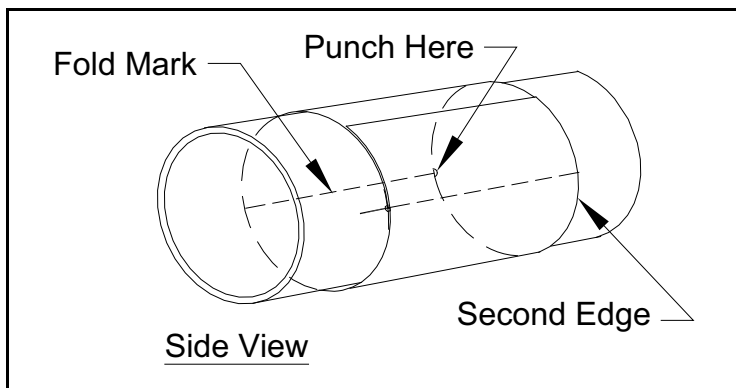

9. Remove the film.
10. Scribe 6" long vertical and horizontal lines that intersect at the center-punch mark.

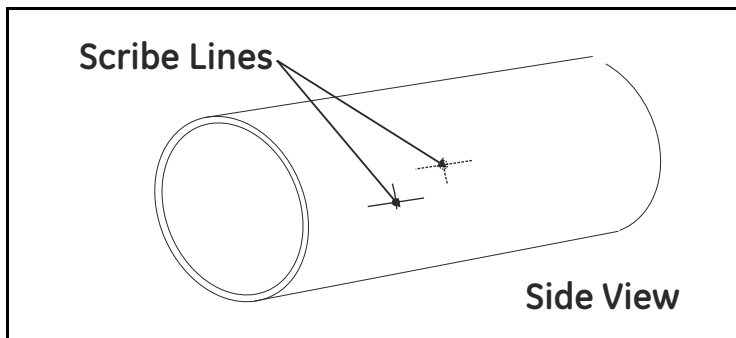

## 2.2.4 Installing the First Welding Boss, Diametrical

1. Before welding the first boss, you must add another scribe line, known as the oblique center line. The oblique center line compensates for the slope or oblique angle of the boss. The oblique center line is offset from the true center (vertical) scribe line marked earlier by a distance of “X,” which is dependent on the pipe outside diameter as follows:

$$X = D/2 - \frac{d/2}{\tan[\sin^{-1}(d/D)]}$$

where, D = pipe outside diameter  
d = welding boss outside diameter (1.660 in.)

Table 1 below shows values of X for various pipe sizes.

**Table 1: X Values for Various Pipe Sizes**

Pipe		X Dimensions
NPS (DN)	O.D.	
12 in. (300 mm)	12.75 in.	0.054 in. (1.37 mm)
14 in. (350 mm)	14.00 in.	0.049 in. (1.24 mm)
16 in. (400 mm)	16.00 in.	0.043 in. (1.09 mm)
18 in. (450 mm)	18.00 in.	0.038 in. (0.97 mm)
20 in. (500 mm)	20.00 in.	0.035 in. (0.89 mm)
22 in. (600 mm)	22.00 in.	0.032 in. (0.81 mm)
24 in. (650 mm)	24.00 in.	0.029 in. (0.74 mm)
26 in. (700 mm)	26.00 in.	0.027 in. (0.68 mm)

2. Scribe the oblique center line on the pipe at the prescribed distance from the true center line. The oblique center line should be marked on the side of the true center line that is closer to the second nozzle location.

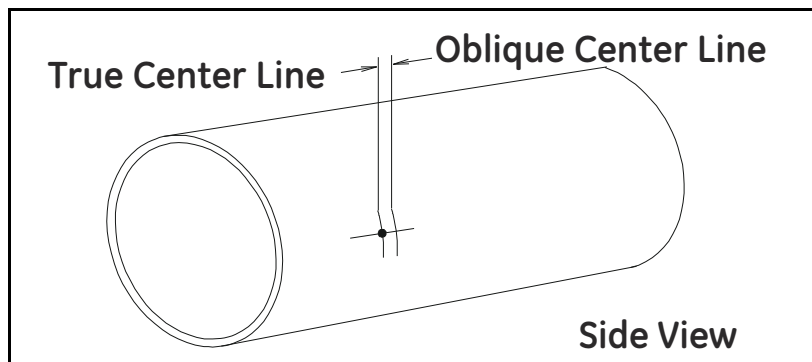

## 2.2.4 Installing the First Welding Boss, Diametrical (cont.)

3. Position the welding boss such that the four scribe lines on the welding boss are lined up with the horizontal scribe mark and the oblique center line on the pipe. Make sure you orient the boss as shown below.

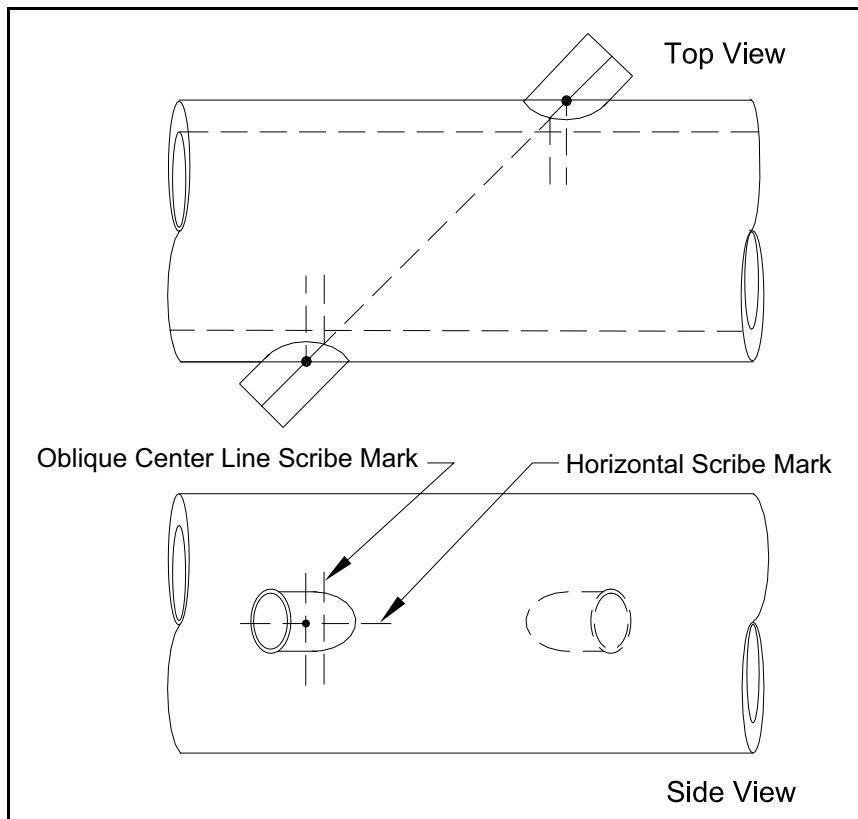

4. Clamp the boss in place using a pipe strap or equivalent so that it cannot move during tack welding.
5. Check the boss alignment, then tack weld the carbon steel boss to the pipe in each of the four grooves between the boss scribe marks.
6. Remove the clamp and check the alignment again. If the boss is misaligned by 0.02 in. (0.5 mm) or more, remove the boss, grind off the welds and reinstall it.

## 2.2.5 Installing the First Nozzle, Diametrical

**IMPORTANT:** *It is essential that the nozzle is set up and fixed in position using the jig and 1-in. threaded rod provided, prior to welding the nozzle.*

1. Screw the threaded rod into boss that is welded onto the pipe. If necessary, remove the washer and nut from the threaded rod.

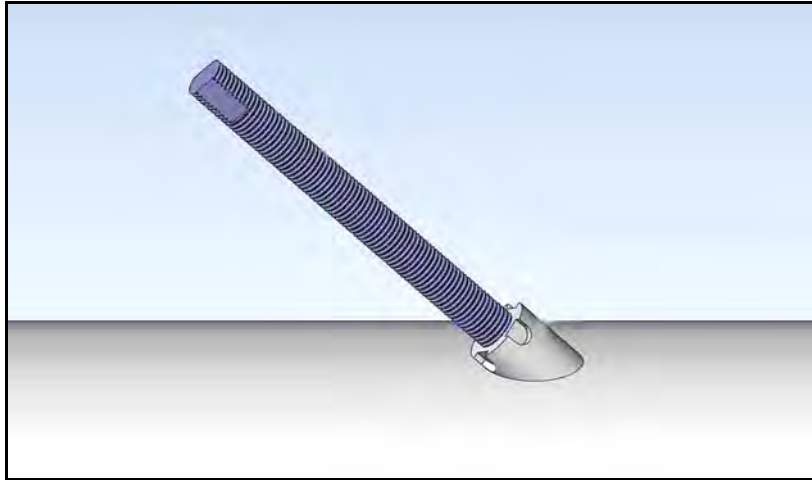

2. Slide the nozzle over the threaded rod, and align the contoured end of the nozzle so it matches the pipe arc. Then slide the jig over the threaded rod, fitting the jig into the welding boss.

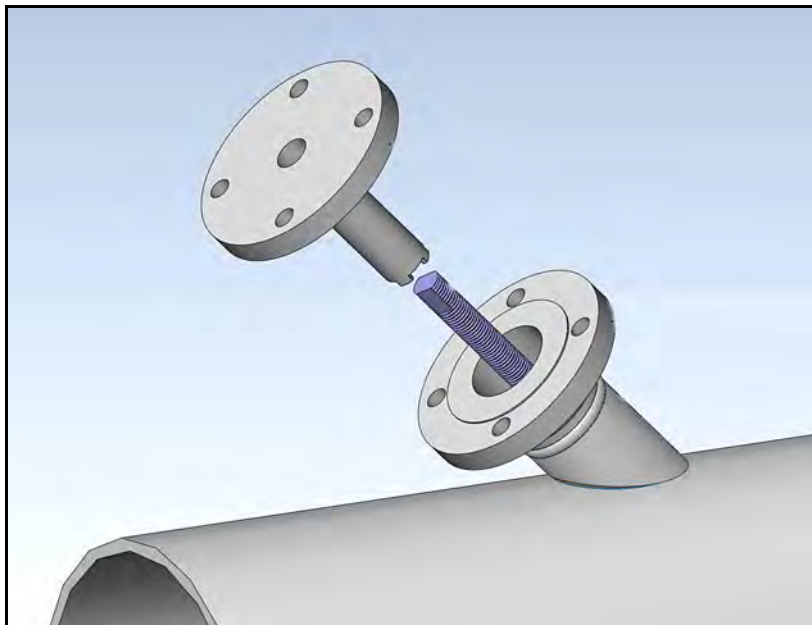

## 2.2.5 Installing the First Nozzle, Diametrical (cont.)

3. Align the jig and nozzle bolt holes and tighten the assembly in place, using the washer and nut.

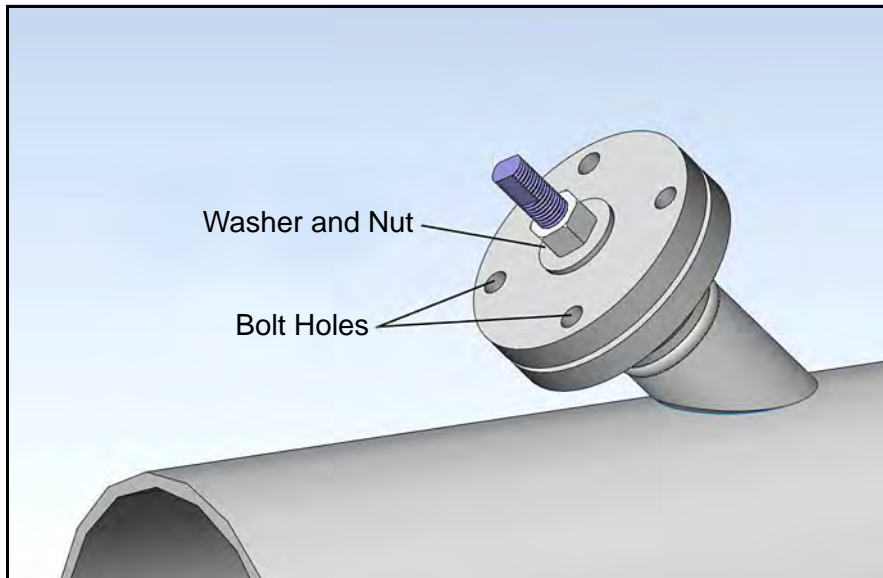

4. Install studs, nuts, and washers in the bolt holes on the flange/jig assembly and tighten the nuts.
5. The jig, boss, and nozzle combination is designed to provide a 0.094 in. (2.4 mm) root gap between the beveled edge of the nozzle and the outside diameter of the pipe. If the 0.094 in. (2.4 mm) clearance does not exist all around, the nozzle must be removed and ground appropriately to provide the required clearance. If the root gap is larger than the 0.094 in. (2.4 mm) dimension, then suitably sized washers may be inserted between the jig and the nozzle to reduce the root gap dimension.



**WARNING!** Only qualified personnel should weld bosses and nozzles, using a suitable ASME BPVC IX qualified welding procedure.

6. Tack weld the nozzle to the pipe at four diametrically opposed points, each tack being approximately 0.6 in. (15 mm) in length. Allow the welds to cool for 30 seconds between tacks.
7. Proceed to complete the root pass and subsequent filler passes as required.
8. Allow the welds to cool, then remove the threaded rod, washer, nut, and jig.

## 2.2.6 Installing the Second Welding Boss and Nozzle, Diametrical

Install the second welding boss and nozzle at the required position as described in “*Installing the First Welding Boss, Diametrical*” on page 11 and “*Installing the First Nozzle, Diametrical*” on page 13.

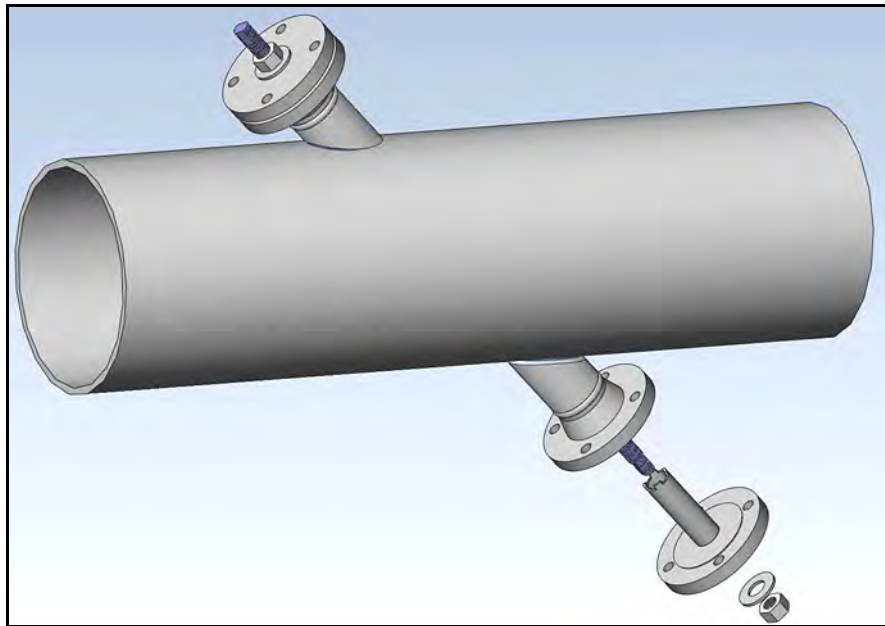

The completed installation should appear as shown below.

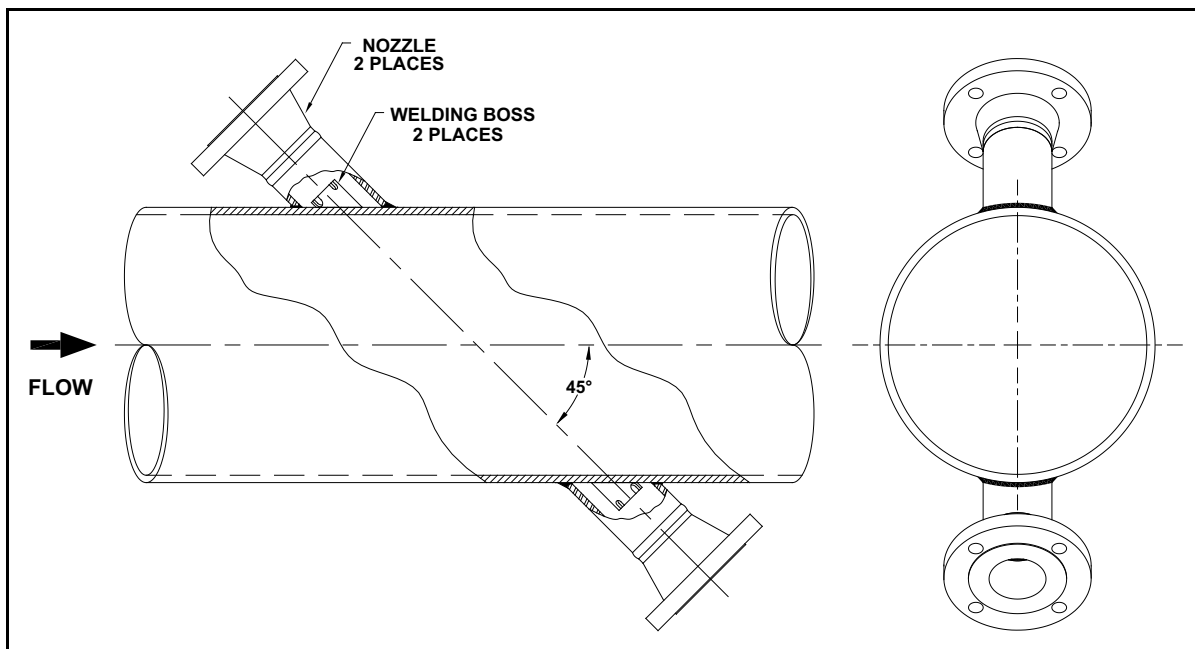

## 2.2.7 Hot Tapping the Pipe



**WARNING!** Hot tapping should be performed only by qualified personnel. Follow all applicable code and safety practices during these procedures.

### ***For 3 in. Flanges:***

1. Install 3 in. ANSI flanged isolation valves on both nozzles (full bore, 8 in. face to face for 150# RF or 11.125 in. for 300# RF) with a gasket and 5/8 in. (for 150# rated flanges) or 3/4 in. (for 300# rated flanges) diameter studs and nuts. Orient the valve handles to minimize interference.
2. Hot tap holes in the pipe using a hot tap machine equipped with a 3/4 in. (19.05 mm) drill bit. Then use a coupon retaining hole saw to cut a hole with a diameter of 2.50 in. (63.5 mm) minimum.

## 2.2.8 Cold Tapping the Pipe



**WARNING!** Cold tapping should be performed only by qualified personnel. Follow all applicable code and safety practices during these procedures.

The procedure for cold tapping a pipe is the same as the hot tapping procedure. However, an isolation valve is not necessary during the process. The hot tapping medium can be applied directly to the nozzle. Isolation valves will be added after the tapping is complete.

## 2.3 Non-Diametrical Mid Radius Path Nozzle Installation

This procedure includes the following instructions:

- Identifying and checking the nozzle installation kit components
- Selecting and marking the first nozzle location
- Determining and marking the second nozzle location
- Installing the first welding Boss
- Installing the first nozzle
- Installing the second welding boss and nozzle
- Hot tapping the pipe



### 2.3.1 Identifying and Checking the Nozzle Installation Kit Components, Non-Diametrical, Mid-Radius

The nozzle kit consists of various components which you must identify and check as described in the following sections.

The *Nozzle Installation Kit* contains the materials listed below. Use *Figure 5* below to help identify each component.

• 2 Nozzles (if purchased)	• 2 Welding bosses	• 1 Jig	• 1 Threaded rod (1 in. diameter), washer and nut
----------------------------	--------------------	---------	---

**IMPORTANT:** *You will need to supply eight 5/8" studs with two nuts each (for 2" 150# flanges, 2" 300# flange or 3" 150# flanges), or 3/4" studs with two nuts each (for 3", 300# flanges).*

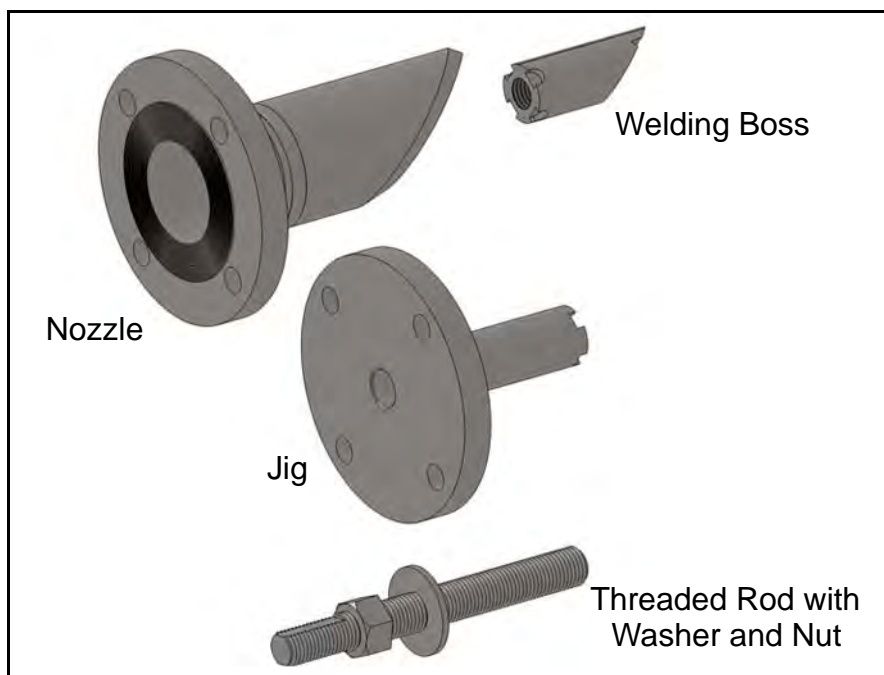
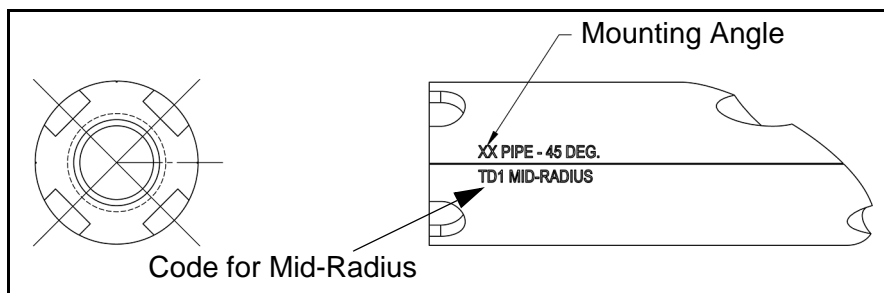

Figure 5: Components for Nozzle Installation Kit

Check the marking on the cylindrical surface of the welding boss. The pipe OD and the mounting angle are engraved on the boss as shown below.



### 2.3.2 Selecting and Marking the First Nozzle Location, Non-Diametrical, Mid-Radius



**CAUTION!** Correct nozzle alignment is critical to the successful operation of the flowmeter; therefore, all marking, positioning and welding operations must be carried out with the utmost attention to accuracy. Unless otherwise stated, dimensional positioning of the nozzles must be held to a tolerance of  $\pm 1/16$  in. ( $\pm 1.6$  mm) relative to each other and with respect to the pipe centerline. the angular tolerance must be held to  $\pm 1^\circ$ .

All hole cutting in process piping must be performed using hot tapping equipment.

1. For optimum performance, you should select a location that has at least 20 pipe diameters of straight, undisturbed flow upstream and 10 pipe diameters of straight, undisturbed flow downstream from the measurement point. Undisturbed flow means avoiding sources of turbulence such as valves, flanges, elbows; avoiding swirl; and avoiding disturbed flow profiles.

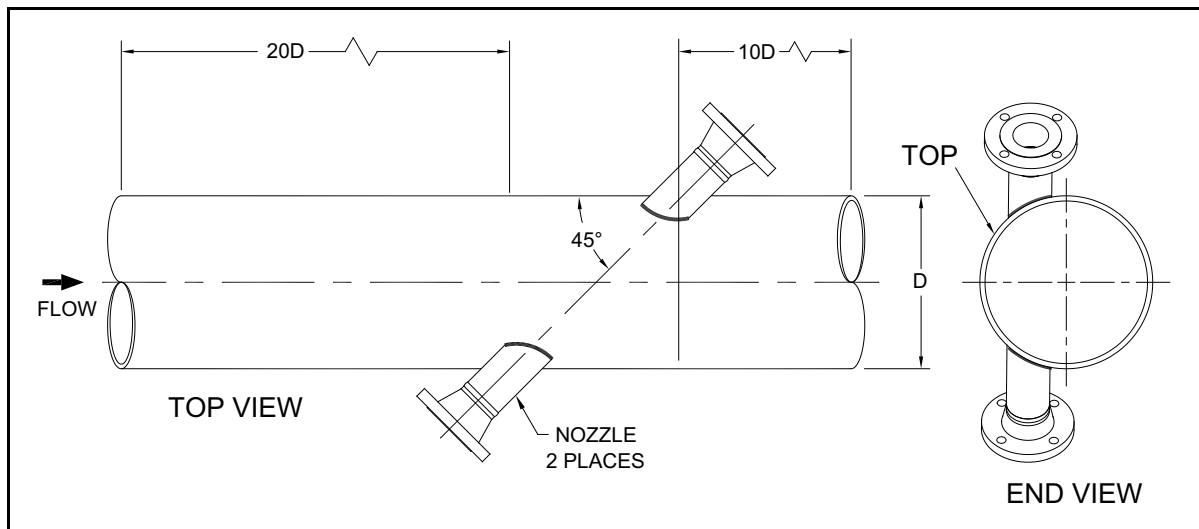

2. We recommend that you install the nozzles on a chord as near as possible to the horizontal plane for horizontal pipe.

**Note:** *If you cannot find a proper location, please consult with GE Flow Application engineering.*

### 2.3.2 Selecting and Marking the First Nozzle Location, Non-Diametrical, Mid-Radius (cont.)

3. Locate the top of the pipe and put a center punch mark there as a reference mark.

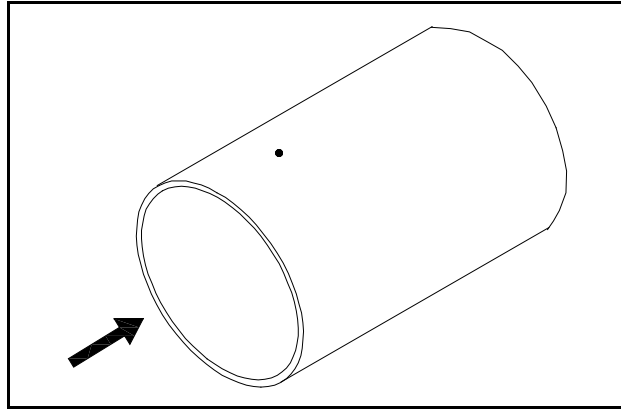

4. Calculate the position for the center of the first nozzle:

$$\frac{AS}{2} = \frac{D}{2} \times \beta$$

where

$$\beta = \text{ATAN}\left(\frac{X_o}{Y_o}\right), \text{ in radian unit}$$

$$Y_o = \left(\frac{D-2W}{2}\right) \times \left(\frac{\text{CHORD}}{\text{LOC}}\right)$$

$$X_o = \sqrt{\left(\frac{D}{2}\right)^2 - Y_o^2}$$

$$\left(\frac{\text{CHORD}}{\text{LOC}}\right) = \frac{1}{2} \text{ (for mid-radius)}$$

2.3.2 Selecting and Marking the First Nozzle Location, Non-Diametrical, Mid-Radius (cont.)

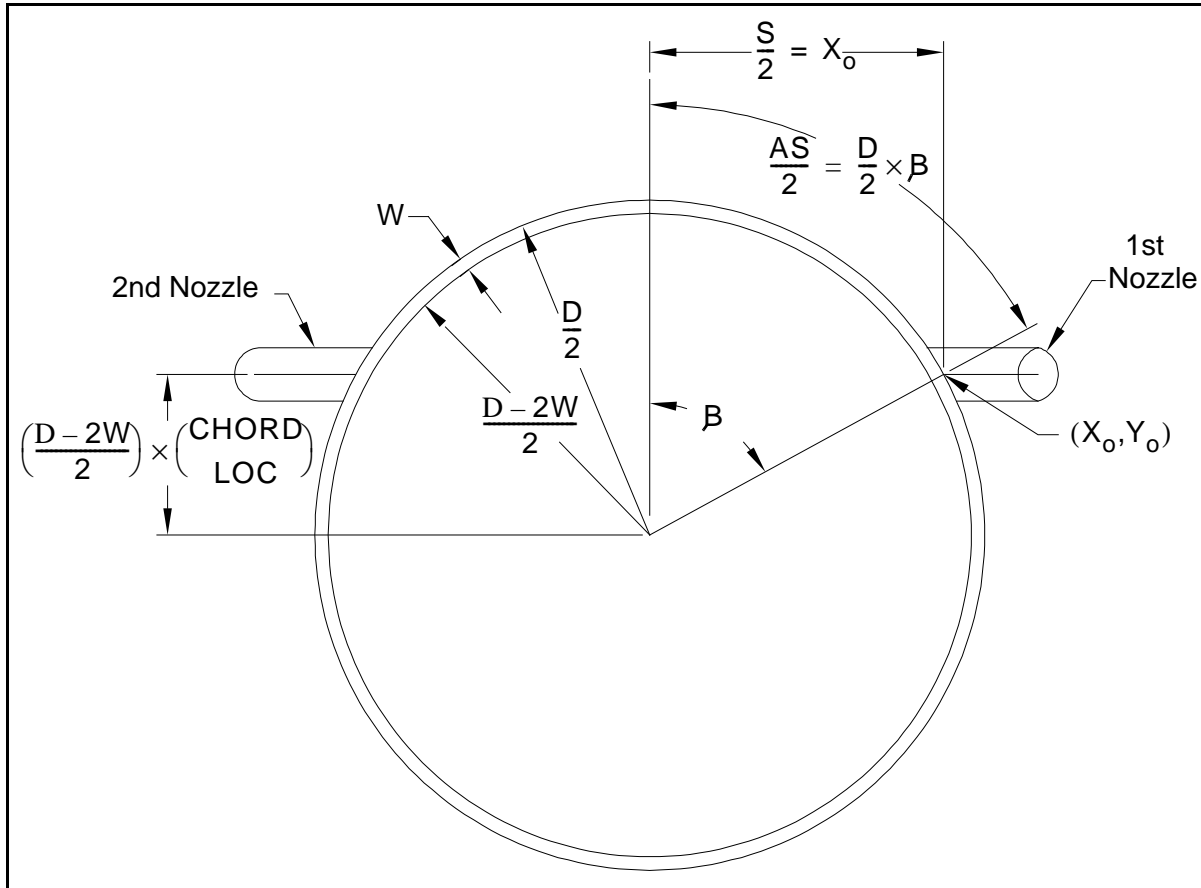

### 2.3.2 Selecting and Marking the First Nozzle Location, Non-Diametrical, Mid-Radius (cont.)

Table 2: AS/2 Values for Various Pipe Sizes with .375" Wall Thickness

Pipe		AS/2 Dimensions
NPS (DN)	O.D.	
26 in. (650mm)	26 in.	13.829 in. (351.26 mm)
28 in. (700mm)	28 in.	14.876 in. (377.86 mm)
30 in. (750mm)	30 in.	15.924 in. (404.46 mm)
32 in. (650mm)	32 in.	16.971 in. (431.06 mm)
34 in.	34 in.	18.018 in. (457.66 mm)
36 in. (900mm)	36 in.	19.065 in. (484.26 mm)
38 in.	38 in.	20.113 in. (510.86 mm)
40 in. (1000mm)	40 in.	21.160 in. (537.46 mm)
42 in. (1050mm)	42 in.	22.207 in. (564.06 mm)
44 in. (1100mm)	44 in.	23.254 in. (590.66 mm)
46 in.	46 in.	24.301 in. (617.26 mm)
48 in. (1200mm)	48 in.	25.349 in. (643.86 mm)
52 in. (1300mm)	52 in.	27.443 in. (697.06 mm)
54 in.	54 in.	28.490 in. (723.65 mm)
56 in. (1400mm)	56 in.	29.538 in. (750.25 mm)
60 in. (1500mm)	60 in.	31.632 in. (803.45 mm)
64 in. (1600mm)	64 in.	33.726 in. (856.65 mm)
66 in.	66 in.	34.774 in. (883.25 mm)

- Using the calculated dimension AS/2 in 4, center punch the pipe to mark the position for the center of the first nozzle.

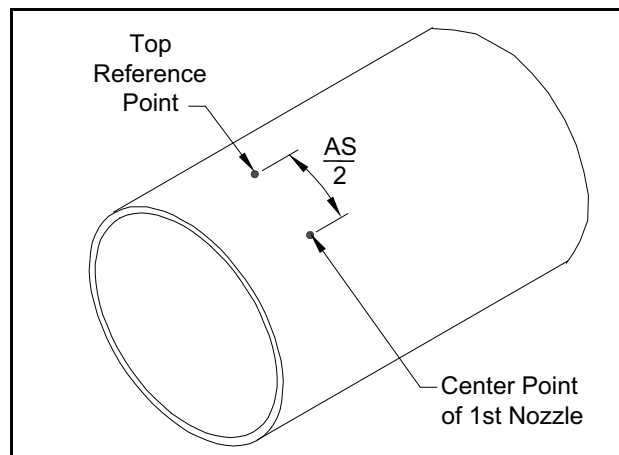

### 2.3.2 Selecting and Marking the First Nozzle Location, Non-Diametrical, Mid-Radius (cont.)

6. Spray this area with a marking dye product. Using a metal edge, scribe 6" long vertical and a horizontal lines that intersect at the center punch mark.

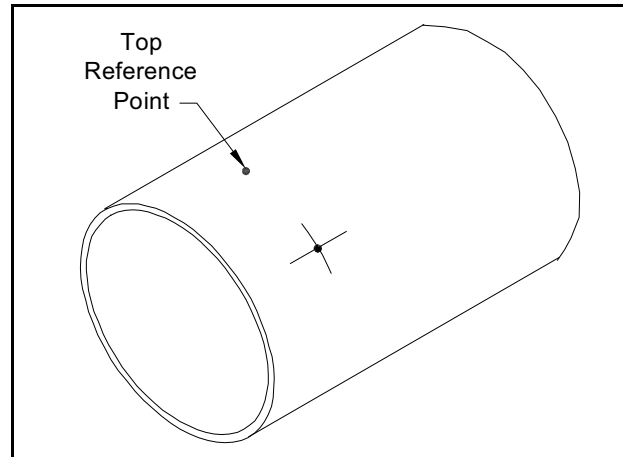

### 2.3.3 Determining and Marking the Second Nozzle Location, Non-Diametrical, Mid-Radius

1. The position for the second nozzle is typically a distance equal to  $S$  along the pipe and located on the other side of the pipe. For installation other than  $45^\circ$ , the distance is equal to  $S$  times the tangent of the installation angle. Steps 2 to 7 on the following pages are for the second nozzle located at  $45^\circ$  from the first nozzle.

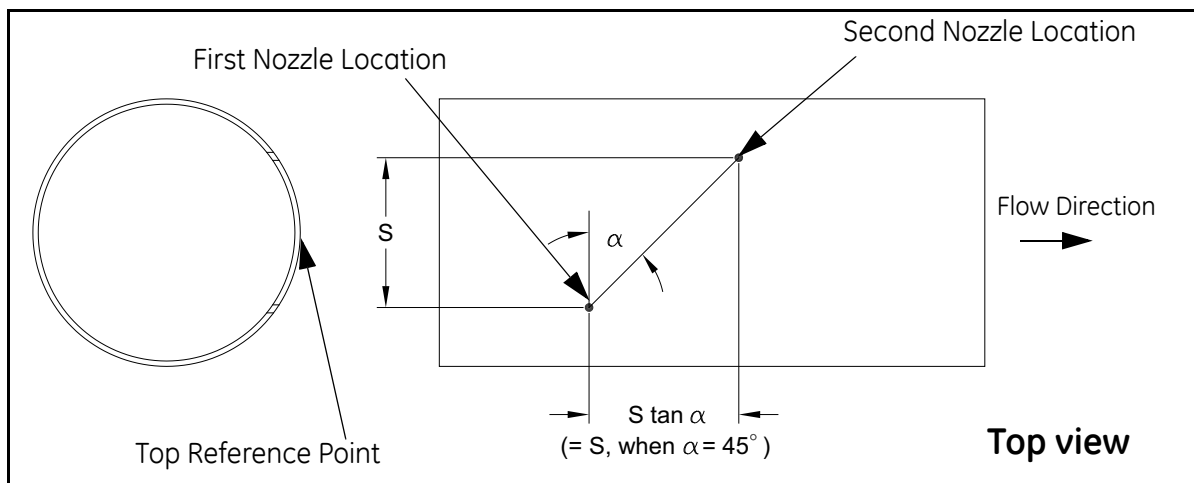

**IMPORTANT:** Follow the convention as depicted in the Top View above. While looking down onto the header pipe, with the flow direction from left to right, the second nozzle should be always located to the right of the first nozzle and the top reference point. The nozzles cannot be mounted on the header pipe if they are located, by mistake, at the mirror image to this convention.

### 2.3.3 Determining and Marking the Second Nozzle Location, Non-Diametrical, Mid-Radius (cont.)

- Due to the possible variation in outside diameter of the pipe, measure the outside diameter of the pipe at four locations between the nozzle centers. Calculate the average outside diameter based on these measurements.

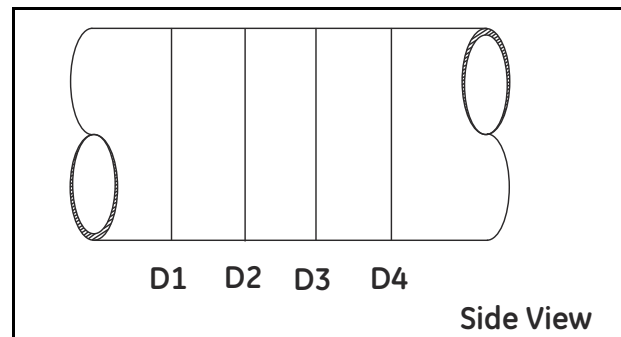

- Using a roll of polyester film (or equivalent), cut a strip of film at the width and length as follows:

**IMPORTANT:** *Ensure that the sides of the film are cut parallel to each other.*

- Width: equal to  $S$  where  $S = 2 \sqrt{\left(\frac{D}{2}\right)^2 - Y_o^2}$  with:

$D$  = average outside diameter calculated in Step 2.

$$Y_o = \left(\frac{D - 2W}{2}\right) \times \left(\frac{\text{Chord}}{\text{Loc}}\right)$$

$$W = 0.375''$$

$$\text{Chord Location} = 0.5$$

- Length: equal to 3.5 times the outside diameter of the pipe.

### 2.3.3 Determining and Marking the Second Nozzle Location, Non-Diametrical, Mid-Radius (cont.)

Then, mark a line at a distance AS from the left edge, where  $AS = D \times \beta$  with:

$D =$  average outside diameter calculated in Step 2.

$$\beta = \text{ATAN}\left(\frac{X_0}{Y_0}\right) \text{ in radian unit}$$

$$Y_0 = \left(\frac{D-2W}{2}\right) \times \left(\frac{\text{Chord}}{\text{Loc}}\right)$$

$$W = 0.375''$$

$$\text{Chord Location} = 1/2$$

$$X_0 = \sqrt{\left(\frac{D}{2}\right)^2 - Y_0^2}$$

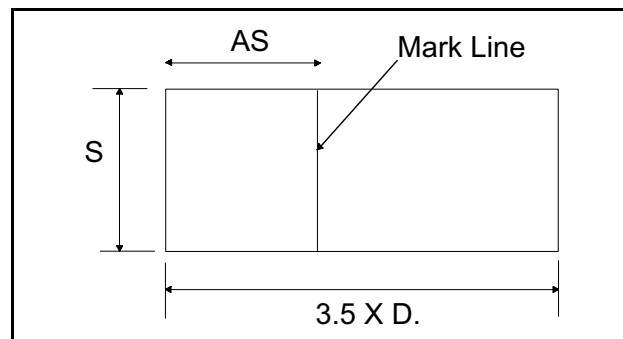



### 2.3.3 Determining and Marking the Second Nozzle Location, Non-Diametrical, Mid-Radius (cont.)

4. Wrap the strip of film around the pipe with one corner edge lined up with the vertical and horizontal scribe lines at the first nozzle location. Make sure the strip overlaps *squarely* around the pipe and that the marked line on the film from step 3 is on the outside and is visible.

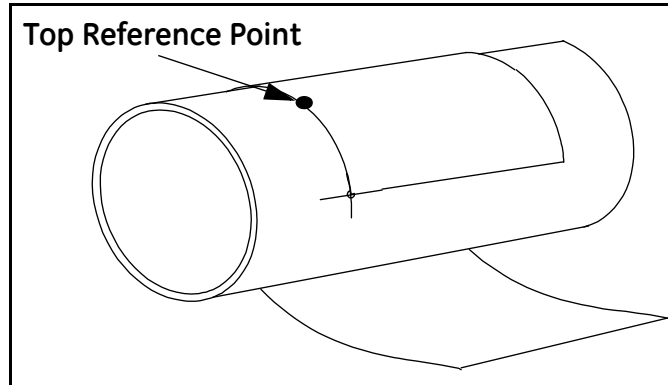

5. The new position for the center of the second nozzle is now identified as the intersection of the mark line and the second edge of the strip of film. Center punch this location prior to removing the strip of film.

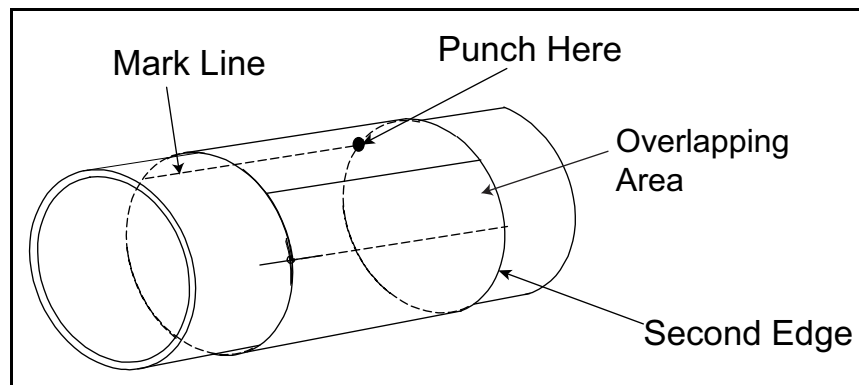

### 2.3.3 Determining and Marking the Second Nozzle Location, Non-Diametrical, Mid-Radius (cont.)

6. Remove the film.
7. Scribe 6" long vertical and horizontal lines that intersect at the center punched area.

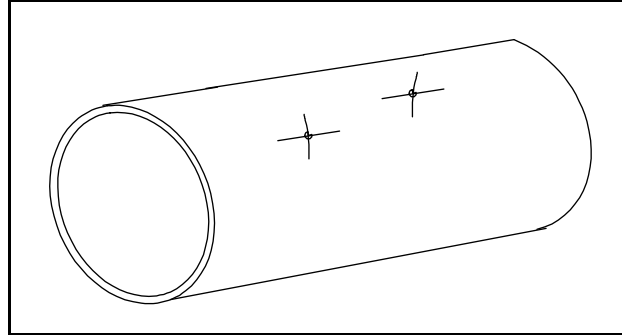

**IMPORTANT:** Follow the illustration closely, due to the non-symmetrical geometry of the off-diameter chord. A mirrored location of both nozzles with respect to a plane either perpendicular or parallel to the pipe in the above illustration will not accommodate the standard supplied Nozzle Installation Kit (NIK) and nozzles.

### 2.3.4 Installing the First Welding Boss, Non-Diametrical, Mid-Radius

1. Before welding the first boss, you must add another scribe line, known as the oblique center line. The oblique center line compensates for the slope or oblique of the boss. The oblique center line is offset from the true center (vertical) scribe line marked earlier by a distance of "X," which is dependent on the pipe outside diameter as follows:

$$X = \sqrt{\left(\frac{D}{2}\right)^2 - Y_0^2} - \sqrt{\left(\frac{D}{2}\right)^2 - Y_1^2}$$

where

D = Pipe outside diameter

$Y_0 = \left(\frac{D-2W}{2}\right) \times (\text{chord location})$

$Y_1 = Y_0 + \frac{d}{2}$

W = 0.375" (default wall thickness)

Chord Location = 1/2 (for mid radius)

d = 1.66 in. welding boss outside diameter

2. Scribe the oblique center line on the pipe from the horizontal line outward, at the prescribed distance from the true center line. The oblique center line should be marked on the side of the true center line that is closer to the second nozzle location. One end of the oblique line should stop at the horizontal line.

### 2.3.4 Determining and Marking the Second Nozzle Location, Non-Diametrical, Mid-Radius (cont.)

**Table 3: Values of X for Various Pipe Sizes with 0.375" Wall Thickness**

Pipe		X Dimensions
NPS (DN)	O.D.	
26 in. (650 mm)	26.00 in.	0.502 in. (12.76 mm)
28 in. (700 mm)	28.00 in.	0.501 in. (12.72 mm)
30 in. (750 mm)	30.00 in.	0.499 in. (12.68 mm)
32 in. (800 mm)	32.00 in.	0.498 in. (12.65 mm)
34 in.	34.00 in.	0.497 in. (12.62 mm)
36 in. (900 mm)	36.00 in.	0.496 in. (12.59 mm)
38 in.	38.00 in.	0.495 in. (12.57 mm)
40 in. (1000 mm)	40.00 in.	0.494 in. (12.55 mm)
42 in. (1050 mm)	42.00 in.	0.493 in. (12.53 mm)
44 in. (1100 mm)	44.00 in.	0.493 in. (12.51 mm)
46 in.	46.00 in.	0.492 in. (12.50 mm)
48 in. (1200 mm)	48.00 in.	0.492 in. (12.49 mm)
52 in. (1300 mm)	52.00 in.	0.491 in. (12.46 mm)
54 in.	54.00 in.	0.490 in. (12.45 mm)
56 in. (1400 mm)	56.00 in.	0.490 in. (12.44 mm)
60 in. (1500 mm)	60.00 in.	0.489 in. (12.42 mm)
64 in. (1600 mm)	64.00 in.	0.488 in. (12.41 mm)
66 in.	66.00 in.	0.488 in. (12.40 mm)

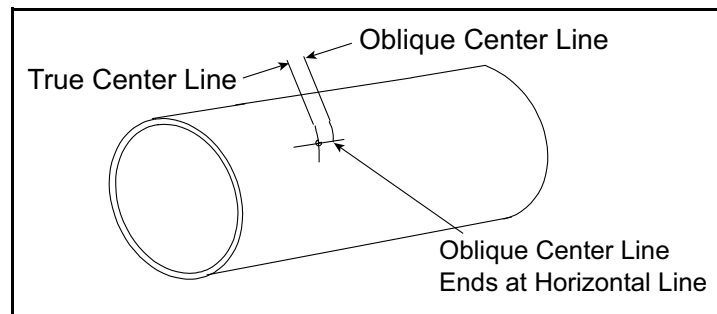

### 2.3.4 Installing the First Welding Boss, Non-Diametrical, Mid-Radius (cont.)

3. Position the welding boss such that the three scribe lines on the welding boss are lined up with the horizontal scribe mark and the oblique center line on the pipe. Make sure you orient the boss as shown below.

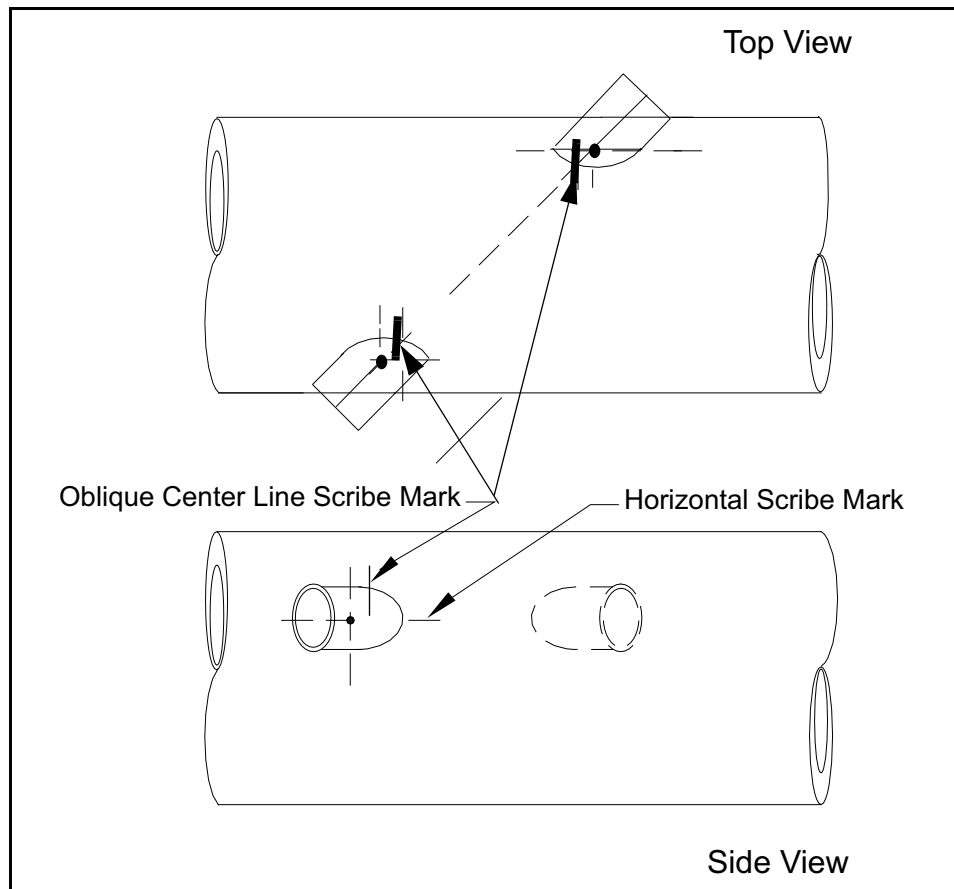

4. Clamp the boss in place using a pipe strap or equivalent so that it cannot move during tack welding.
5. Check the boss alignment, then tack weld the carbon steel boss to the pipe in each of the four grooves between the boss scribe marks.
6. Remove the clamp and check the alignment again. If the boss is misaligned by 0.02 in. (0.5 mm) or more, remove the boss, grind off the welds and reinstall it.

### 2.3.5 Installing the First Nozzle, Non-Diametrical Mid Radius

**IMPORTANT:** *It is essential that the nozzle is set up and fixed in position using the jig and 1-in. threaded rod provided, prior to welding the nozzle.*

1. Screw the threaded rod into a boss that is welded onto the pipe. If necessary, remove the washer and nut from the threaded rod.

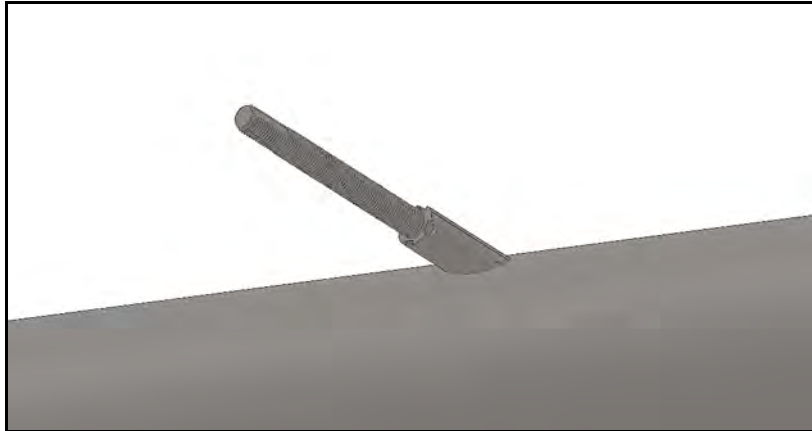

2. Slide the nozzle over the threaded rod, and align the contoured end of the nozzle so that it matches the pipe arc. Then slide the jig over the threaded rod, fitting the jig into the welding boss.

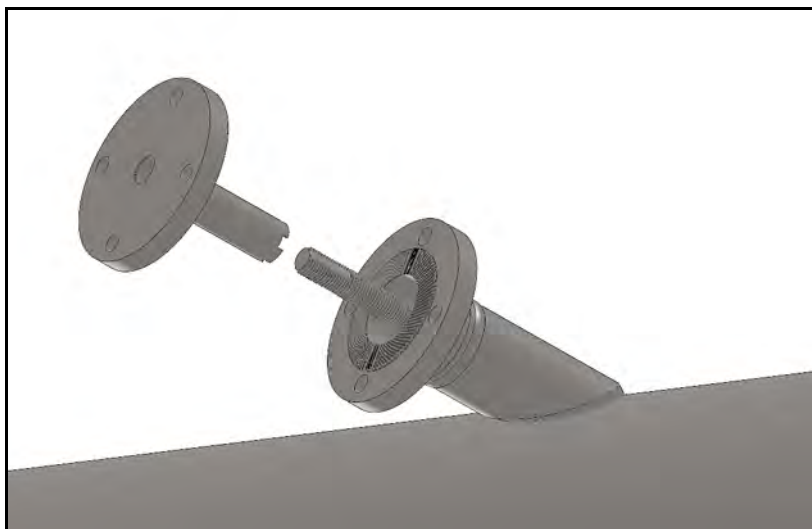

### 2.3.5 Installing the First Nozzle, Non-Diametrical Mid Radius (cont.)

3. Align the jig and nozzle bolt holes and tighten the assembly in place, using the washer and nut.

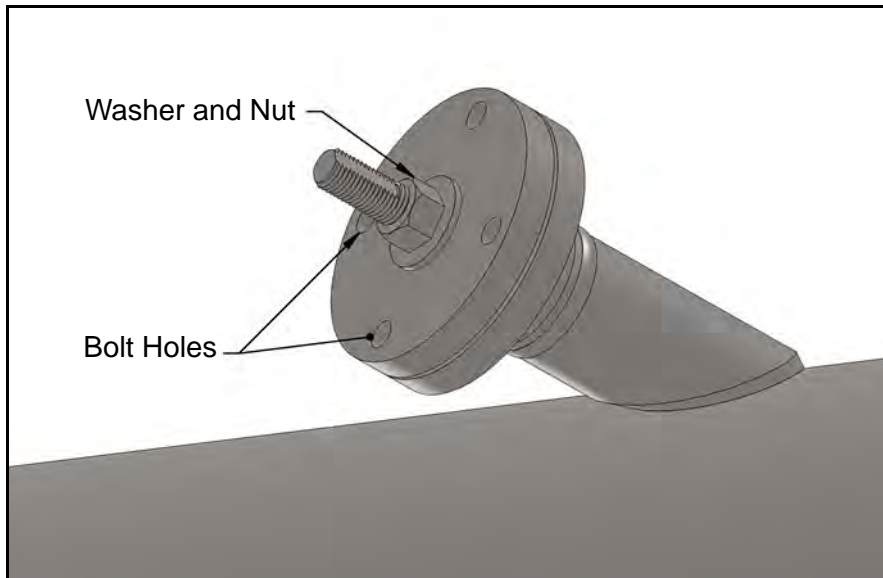

4. Install studs, nuts, and washers in the bolt holes on the flange/jig assembly and tighten the nuts.
5. The jig, boss, and nozzle combination is designed to provide a 0.094 in. (2.4 mm) root gap between the beveled edge of the nozzle and the outside diameter of the pipe. If the 0.094 in. (2.4 mm) clearance does not exist all around, the nozzle must be removed and ground appropriately to provide the required clearance. If the root gap is larger than the 0.094 in. (2.4 mm) dimension, then suitably sized washers may be inserted between the jig and the nozzle to reduce the root gap dimension.



**WARNING!** Only qualified personnel should weld bosses and nozzles, using a suitable ASME BPVC IX qualified welding procedure.

6. Tack weld the nozzle to the pipe at four diametrically opposed points, each tack being approximately 0.6 in. (15 mm) in length. Allow the welds to cool for 30 seconds between tacks.
7. Proceed to complete the root pass and subsequent filler passes as required.
8. Allow the welds to cool, then remove the threaded rod, washer, nut, and jig.

### 2.3.6 Installing the Second Welding Boss and Nozzle, Non-Diametrical Mid Radius

Install the second welding boss and nozzle at the required position as described in *Installing the First Welding Boss* and *Installing the First Nozzle*.

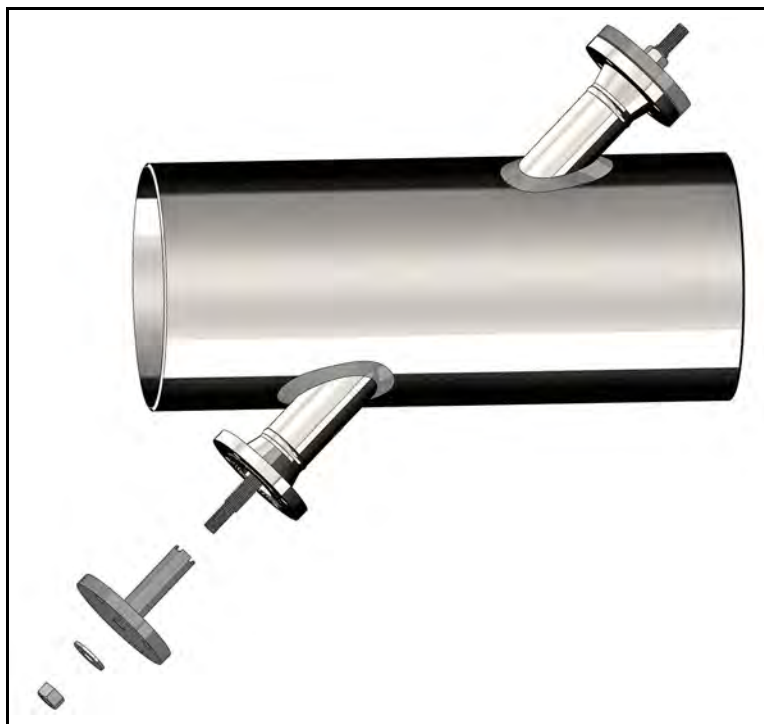

The completed installation should appear as shown below.

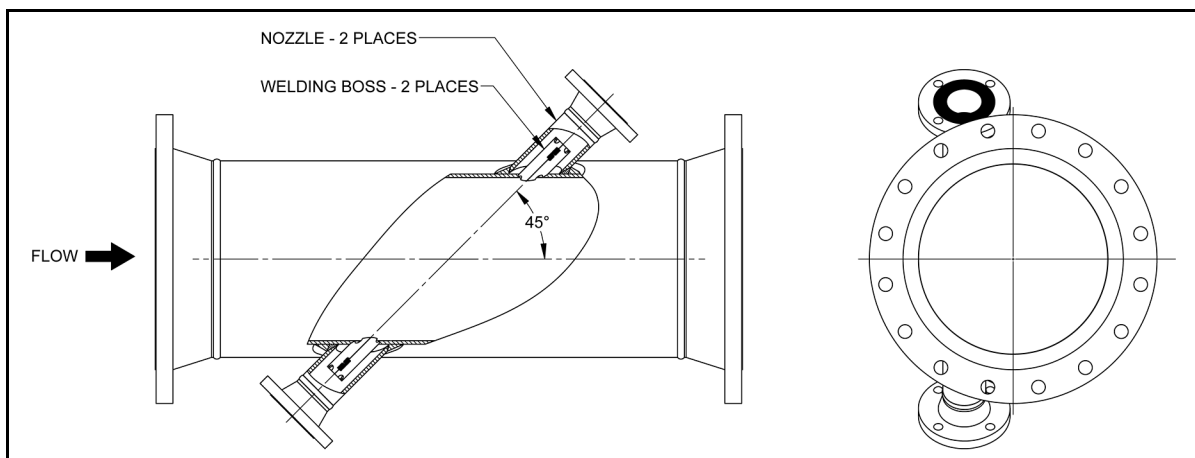

### 2.3.7 Hot Tapping the Pipe



**WARNING!** Hot tapping should be performed only by qualified personnel. Follow all applicable code and safety practices during these procedures.

#### ***For 3 in. Flanges:***

1. Install 3 in. ANSI flanged isolation valves on both nozzles (full bore, 8 in. face to face for 150# RF or 11.125 in. for 300# RF) with a gasket and 5/8 in. (for 150# rated flanges) or 3/4 in. (for 300# rated flanges) diameter studs and nuts. Orient the valve handles to minimize interference.
2. Hot tap holes in the pipe using a hot tap machine equipped with a 3/4 in. (19.05 mm) drill bit. Then use a coupon retaining hole saw to cut a hole with a diameter of 2.50 in. (63.5 mm) minimum.

### 2.3.8 Cold Tapping the Pipe



**WARNING!** Cold tapping should be performed only by qualified personnel. Follow all applicable code and safety practices during these procedures.

The procedure for cold tapping a pipe is the same as the hot tapping procedure. However, an isolation valve is not necessary during the process. The hot tapping medium can be applied directly to the nozzle. Isolation valves will be added after the tapping is complete.



## Chapter 3. Installing an Isolation Valve

**Note:** This chapter describes how to install an isolation valve onto a nozzle for applications using the flare gas insertion mechanism.

### 3.1 Diametrical or Non-Diametrical Nozzle, Valve Installation

#### 3.1.1 For 3 inch Flanges

Refer to *Figure 6* below and install 3 inch ANSI flanged full-bore isolation valves on both nozzles (8 in. face to face for 150# RF flanges or 11.125 in. for 300# RF flanges) with a gasket and 5/8 in. (for 150# rated flanges) or 3/4 in. (for 300# rated flanges) diameter studs and nuts. Orient the valve handles to minimize interference.

**Note:** This installation of the isolation valves may have been accomplished already during the hot tapping operation.

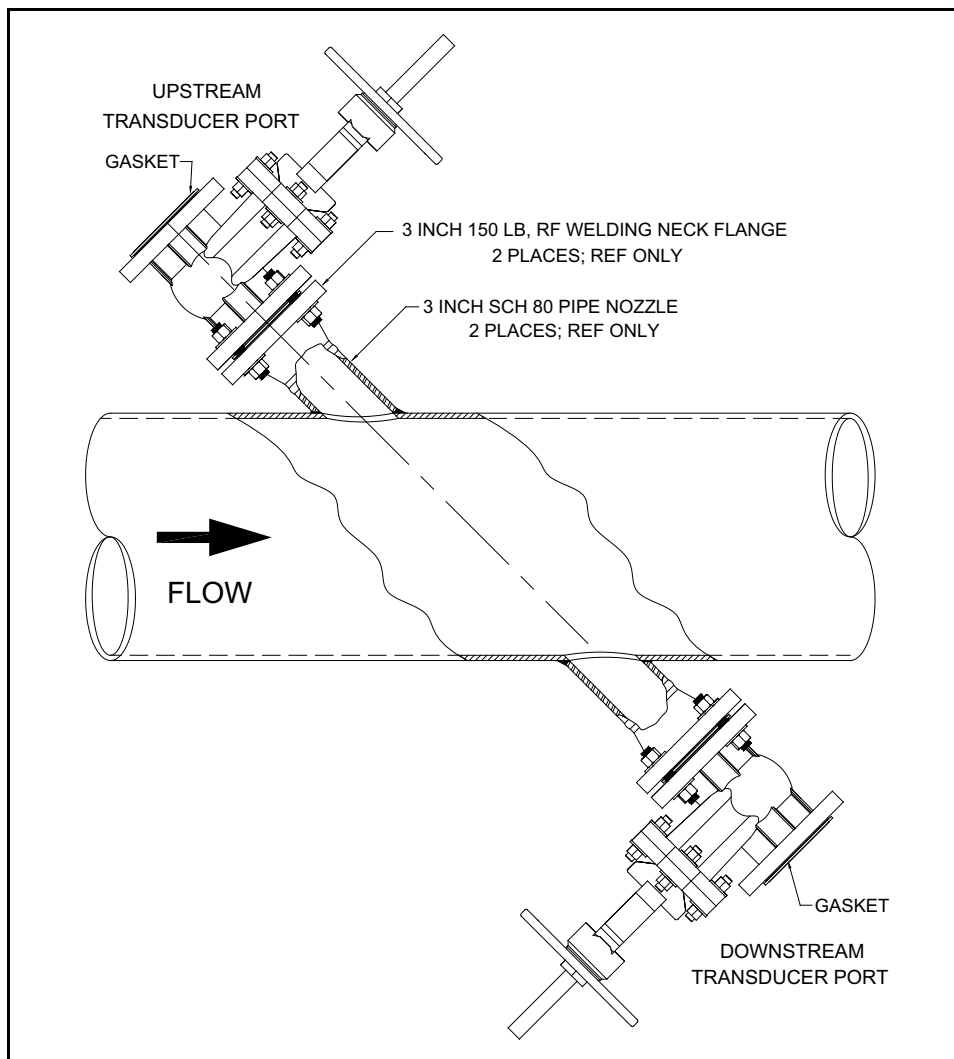

Figure 6: Installation of Isolation Valves - Standard Assembly

[no content intended for this page]

## Chapter 4. Inserting T17 Transducers into the Pipe

### 4.1 Introduction

The T17 transducer is typically installed into a meter body. The meter body is a section of pipe that contains the ports where the transducers will be mounted. The meter body may be prefabricated or created by installing ports on the existing pipe. The T17 is inserted using a packing gland-based, low-pressure insertion mechanism.

### 4.2 Inserting Transducers Using the Insertion Mechanism

The *Insertion Mechanism* is designed for manual (non-assisted) transducer insertion into operating or pressurized pipes. Before inserting the mechanism, you must have isolation valves mounted to nozzles in the meter body.

Inserting the transducers into the pipe consists of the following:

- Preparing for Installation
- Mounting the Insertion Mechanism
- Inserting the Transducer into the Pipe
- Aligning the Transducers



**WARNING!** The manual insertion mechanism system is for low-pressure applications (80 psig/5.5Bar or less). Use the appropriate safety precautions when inserting or withdrawing the insertion mechanism.

#### 4.2.1 Preparing for Installation

Before you begin, you should find an area where you can place the insertion mechanism upright without placing any weight on the transducer (e.g., a bench with a cutout large enough to slide the transducer through).

You will need the following items for installation:

- A packing tool (may be shipped with the electronics)
- A gasket to place on the isolation valve
- A straight edge ruler/scale
- A tag to place on the isolation valve
- Bolts

## 4.2.2 Mounting the Insertion Mechanism

1. Before mounting the mechanism on the isolation valve, refer to *Figure 7* below to familiarize yourself with its components:
  - junction box
  - barrel
  - packing gland
  - transducer

**Note:** *Explosion-proof boxes may not be mounted on the end of a transducer during shipment.*

**IMPORTANT:** *For an extended range operation meter, the upstream and downstream transducers are different, and it is crucial to the meter operation that the correct transducer be installed in the correct location. The upstream transducer has a 180° head, the downstream transducer has a 6° offset, or 174° head, and the insertion mechanism and transducer have alignment marks.*

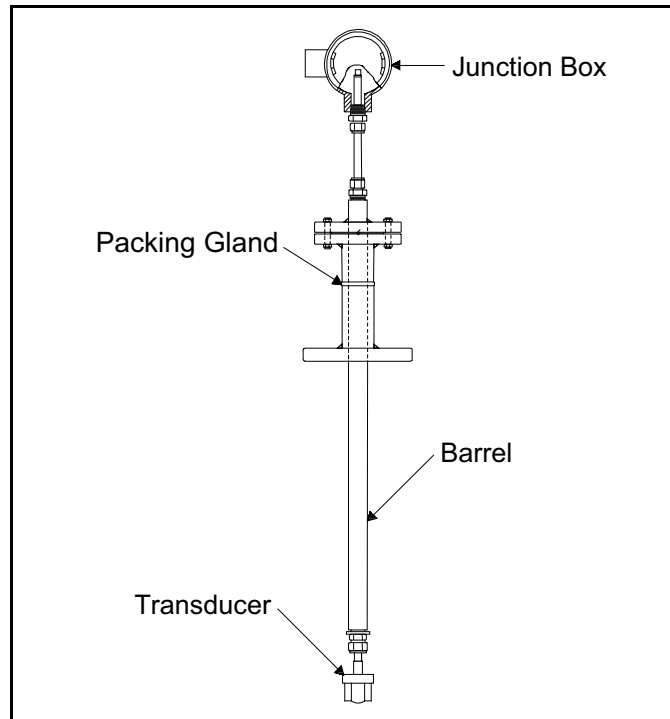
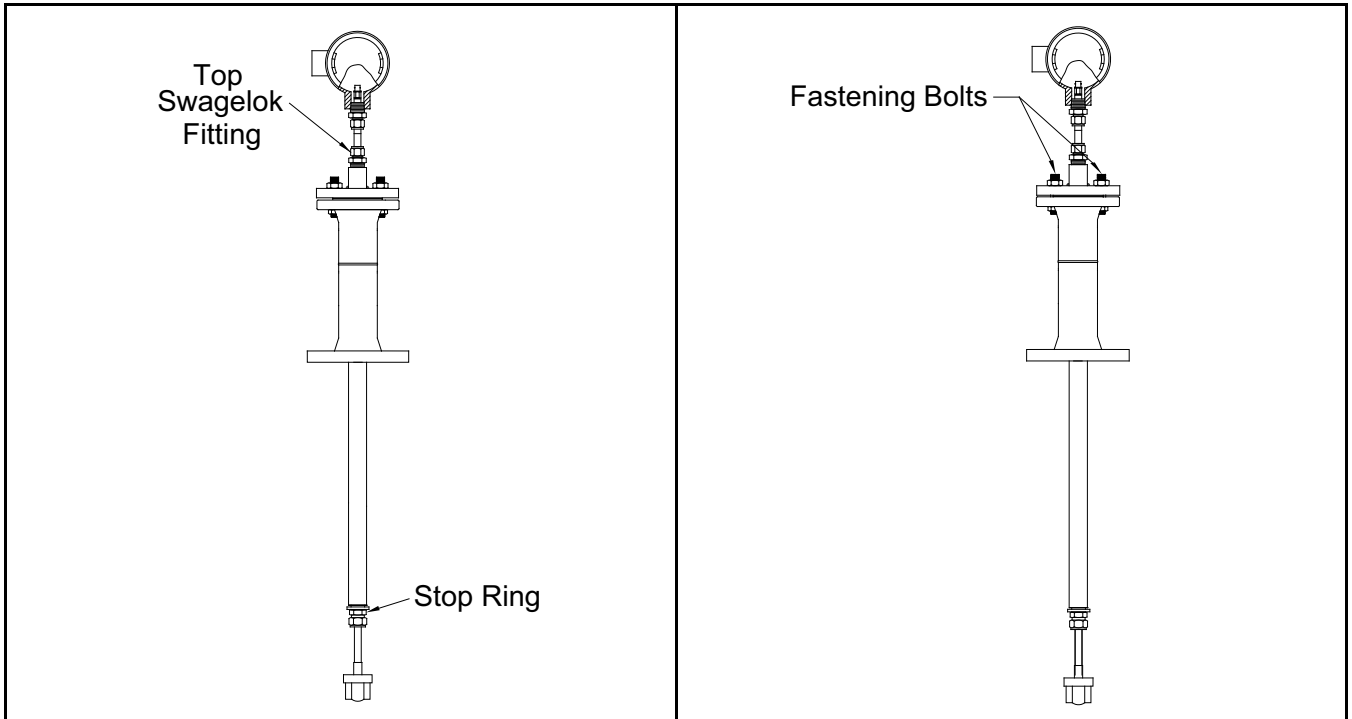

Figure 7: Insertion Mechanism Assembly with T17 Transducer

### 4.2.2 Mounting the Insertion Mechanism (cont.)

2. Visually inspect the transducer to make sure the top Swagelok® fitting is not loose.

**IMPORTANT:** *The stop ring at the end of the barrel is supposed to be loose. DO NOT tighten the Swagelok® fitting or you could change the transducer alignment.*



3. Remove the four bolts that fasten the barrel to the packing gland.

**Note:** *Swagelok® is a registered trademark of the Swagelok Company.*

## 4.2.2 Mounting the Insertion Mechanism (cont.)

4. Retract the barrel from the packing gland so that the transducer head is recessed in the packing gland. You will hear the stop ring click when the transducer is fully recessed.

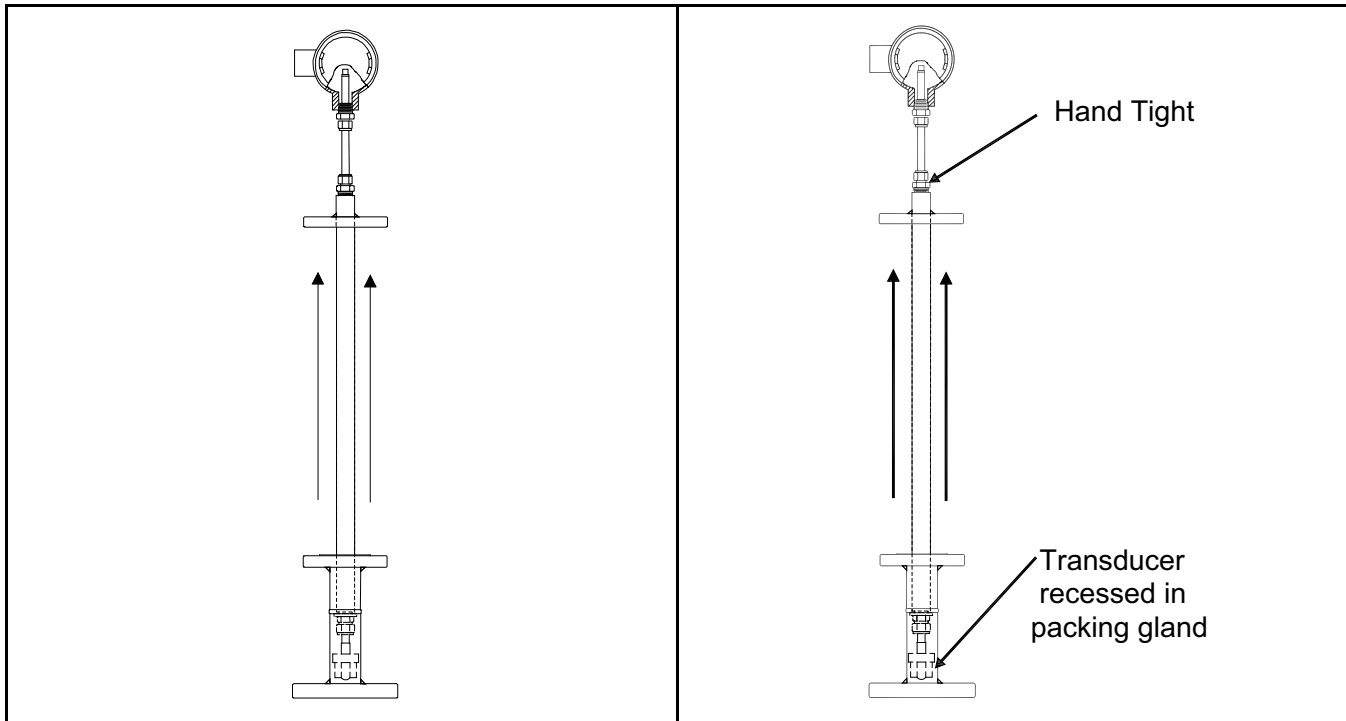

5. Visually inspect the mechanism to make sure the transducer is recessed in the packing gland. Again, make sure the top Swagelok<sup>®</sup> fitting is secure and hand tight.

#### 4.2.2 Mounting the Insertion Mechanism (cont.)

6. Lift the gasket and insert the packing tool into the packing nut. Turning the packing tool clockwise, tighten the packing material so that the barrel stays up without support.

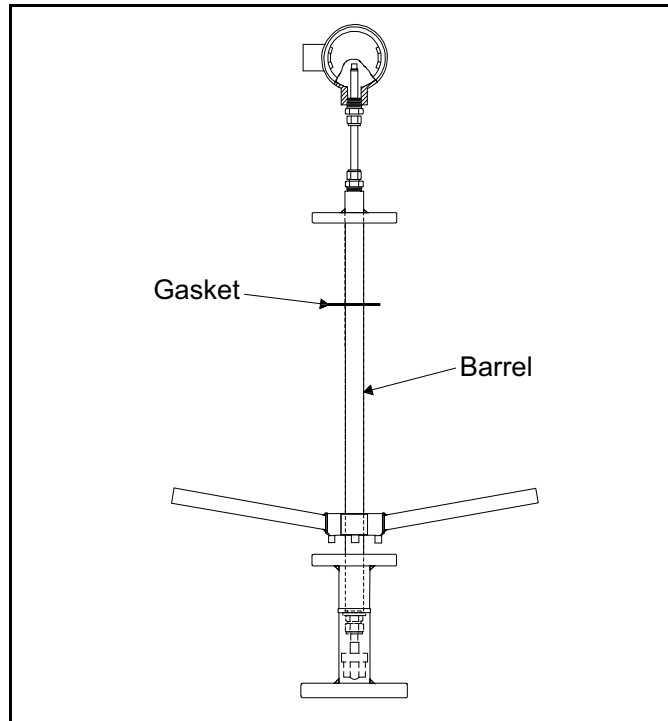

7. Place a gasket on the isolation valve.

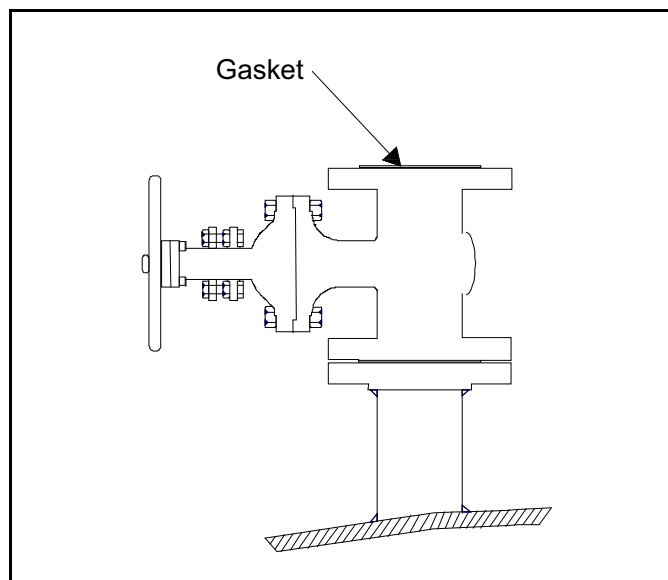

## 4.2.2 Mounting the Insertion Mechanism (cont.)

8. Identify the upstream and downstream transducer assemblies.

For *Standard Velocity Range* applications, the upstream and downstream nozzle designations are interchangeable. The system is bi-directional.

For *Extended Velocity Range* applications, the system is not bi-directional. Note which valve is designated upstream and downstream on the pipe. Identify the upstream and downstream insertion mechanism assemblies. The downstream assembly is labeled with an alignment mark on the *Barrel flange*, and an associated scribe line on the *transducer tube* near the connector end (see the figure below).

The downstream transducer head is angled  $6^\circ$  and must face into the flow.

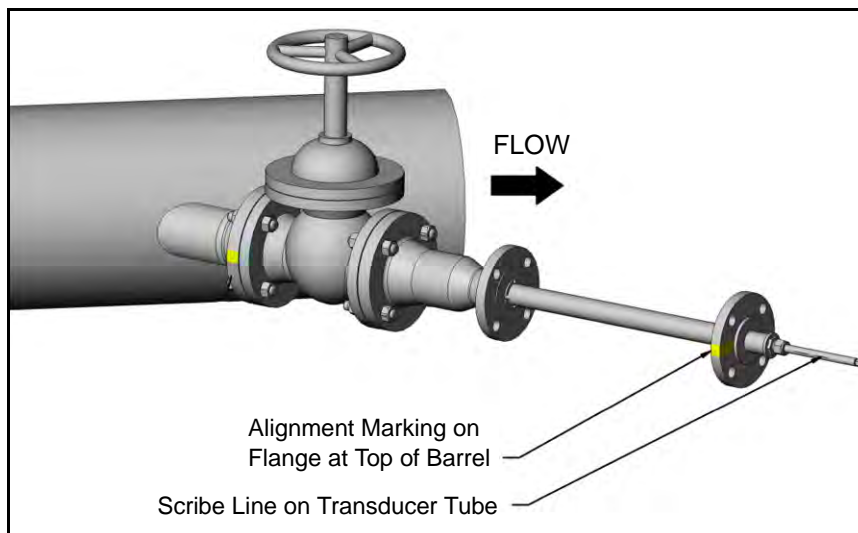

9. Proceed with either the upstream or downstream assembly.



## 4.2.2 Mounting the Insertion Mechanism (cont.)

10. Lift the insertion mechanism by the barrel and place the insertion mechanism on the isolation valve.

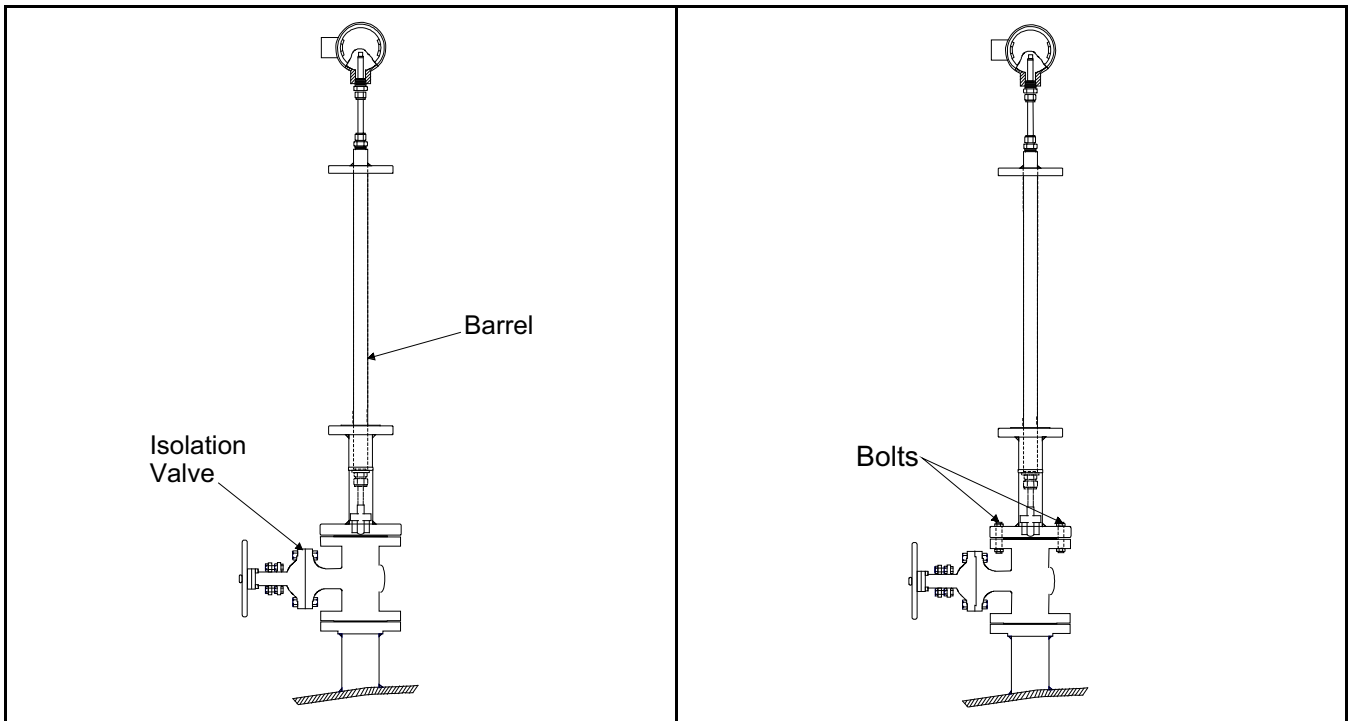

11. Line up the flange holes and bolt the packing gland to the isolation valve.

## 4.2.2 Mounting the Insertion Mechanism (cont.)

12. Using the packing tool, tighten the packing nut again until the nut is recessed.



**WARNING!** The packing material must be securely packed before the isolation valve is opened.

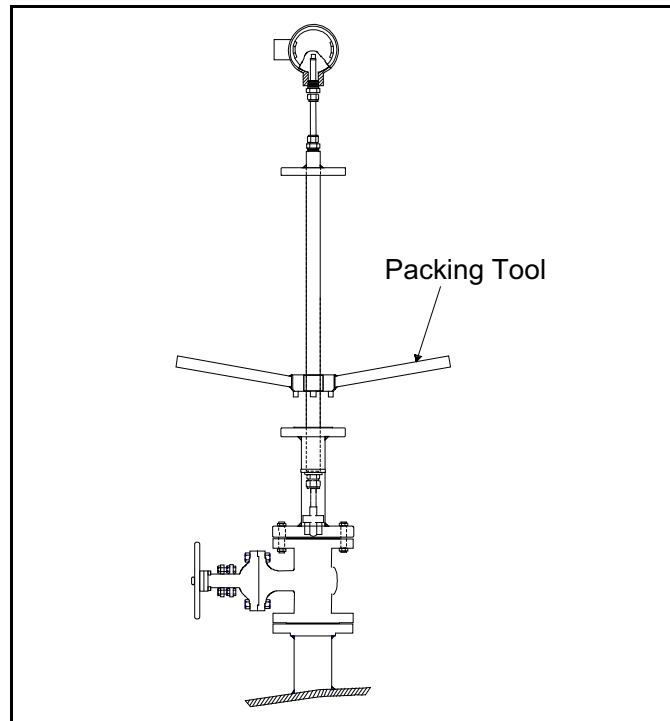

### 4.2.3 Aligning the Downstream Transducer for Extended Range Installations

For extended velocity range applications, the head of the downstream transducer is angled at  $6^\circ$  so that it points upstream (into the flow) by  $6^\circ$ . This allows the ultrasonic signal to be pushed into alignment at very high flow rates. At low flow rates, the beam is wide enough to tolerate the initial  $6^\circ$  misalignment.

**Note:** *Only the downstream transducer flange alignment is crucial to the functionality of the meter. For installation of the upstream transducer, see “Mounting the Insertion Mechanism” on page 36.*

**Note:** *This step of the installation requires two people. One person should support the barrel and one person should operate the alignment fixture.*

**Note:** *Although the images in this section do not show the gasket referenced in “Preparing for Installation” on page 35, that gasket is crucial to sealing the assembly.*

1. Locate the supplied alignment tool shown below (part number 568-120). This tool is used to check and possibly fine-tune the alignment by rotating the Barrel assembly prior to final tightening of the mounting nuts and studs.

**Note:** *Although this process ensures optimum performance, it is not required for proper operation.*



2. Find the scribe line on the downstream transducer tube near the transducer end with the BNC connector. This scribe line indicates the direction of the angled transducer head. Verify by direct observation that the scribe line on the transducer lines up with the alignment marking on the flange at the top of the Barrel. If it does not, contact GE for assistance.

### 4.2.3 Aligning the Downstream Transducer (cont.)

3. The primary method for ensuring that the angled transducer head is pointing in the correct direction uses the alignment marks on the downstream nozzle and the downstream Barrel assembly (see the figure below). The alignment marking on the flange at the top of the Barrel must be in alignment with the nozzle, such that the marking falls between the bolt holes straddling the upstream to downstream centerline, as shown below.

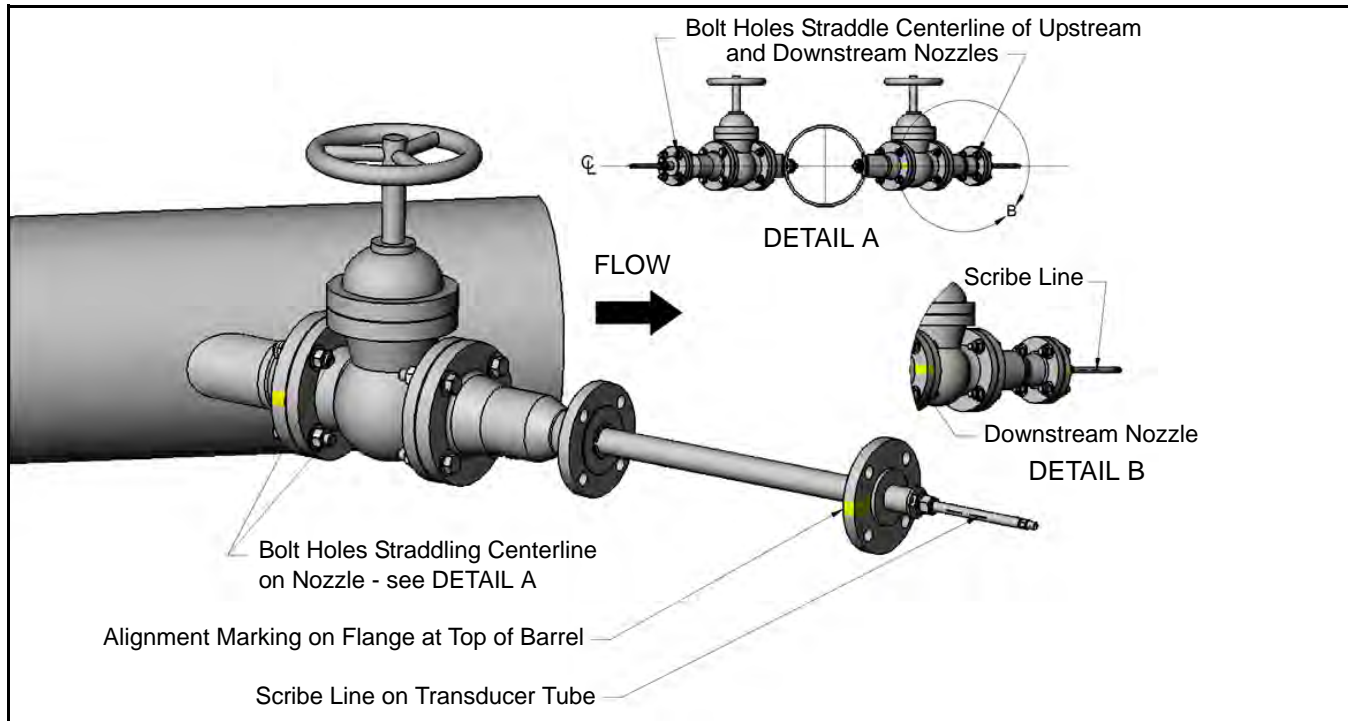

### 4.2.3 Aligning the Downstream Transducer (cont.)

- Before proceeding, verify that the valve and insertion mechanism are fully bolted in place. Each stud should extend far enough beyond its nut to allow the alignment tool to rest on the stud. Fit the alignment fixture over the nozzle studs so that the two studs straddling the centerline on the nozzle are inserted into the holes on the fixture of the corresponding flange size and rating (3", 150# or 300#).

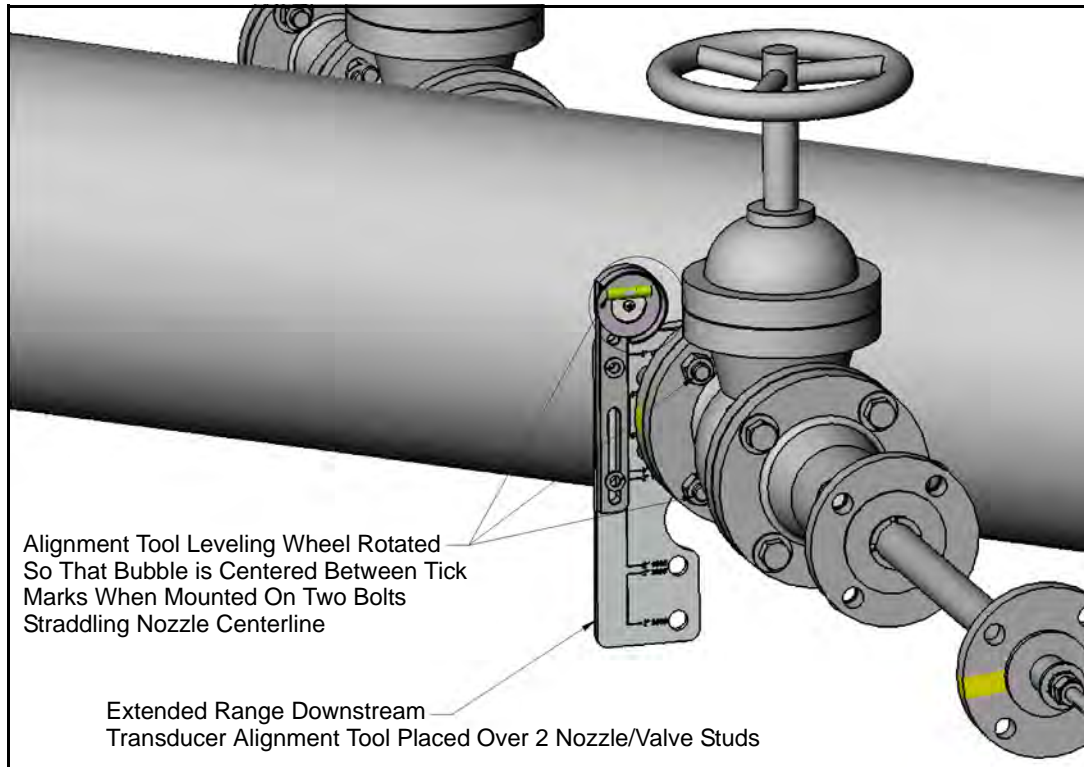

- Adjust the leveling wheel so that the bubble in the level is centered between the two tick marks on the vial.

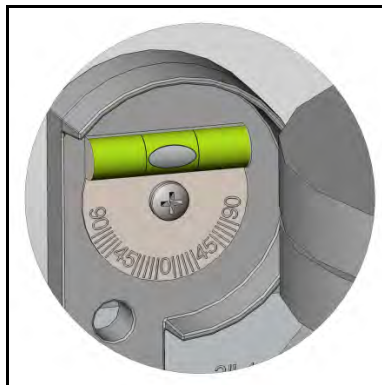

- Remove the alignment fixture from nozzle studs.
- Place two sets of studs, washers and nuts into the flange at the top of barrel assembly, straddling the alignment mark. Nuts and washers should not be installed on the side of the flange with the serrated raised face.

### 4.2.3 Aligning the Downstream Transducer (cont.)

8. Place the alignment fixture over the two studs in the flange at the top of the barrel assembly, and rotate the barrel flange until the bubble aligns between the tick marks on the vial. Slowly press the flange toward the insertion mechanism flange until the gasket and raised faces of both flanges are mated. The studs should also engage the holes in the insertion mechanism flange. If desired, the barrel flange can be rotated slightly to maintain the bubble alignment on the gauge.

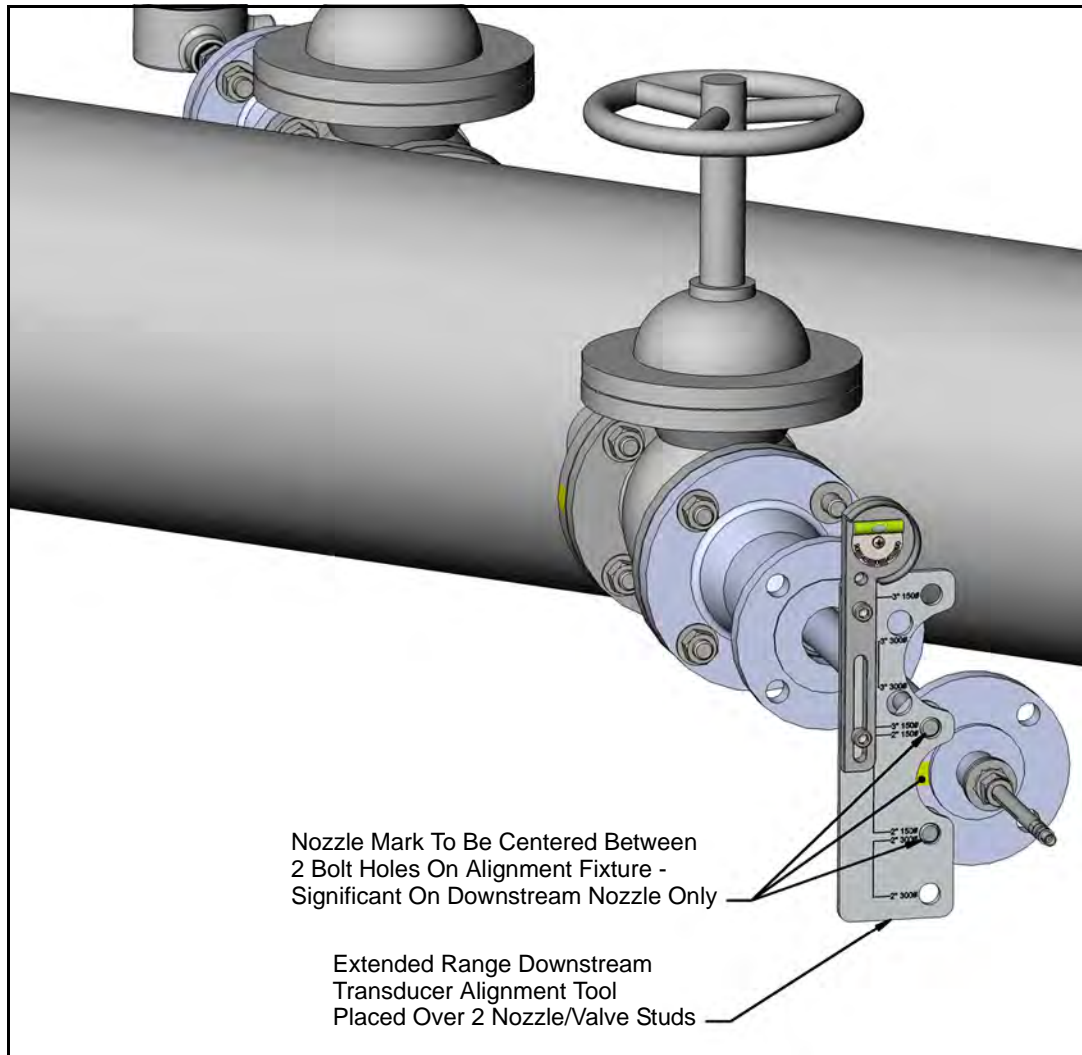

9. Remove the fixture and install the remaining studs, washers, and nuts. Tighten them to the correct torque.
10. Place a tag on the isolation valve stating the following:

**DO NOT OPERATE (CLOSE) WHEN  
TRANSDUCER IS INSERTED INTO PIPE.**

11. Refer to the flowmeter *Startup Guide* to make the transducer electrical connections.

### 4.3 Connecting an XAMP

This section explains how to correctly install and assemble an **XAMP** into a transducer junction box. Although one type of junction box is used as an example in the steps below, the procedure applies to all three possible junction box options (refer to drawing #752-063, *Figure 16 on page 51*).

1. Place a 3/4" NPT compression fitting on the stem of the transducer closer to the BNC end.
2. Torque the fitting into one of the 3/4" NPT ports of the junction box, with at least five threads engaged. After the fitting is torqued into place, ensure that the BNC head of the transducer extends slightly past the ground screw bosses as shown in *Figure 8* below:

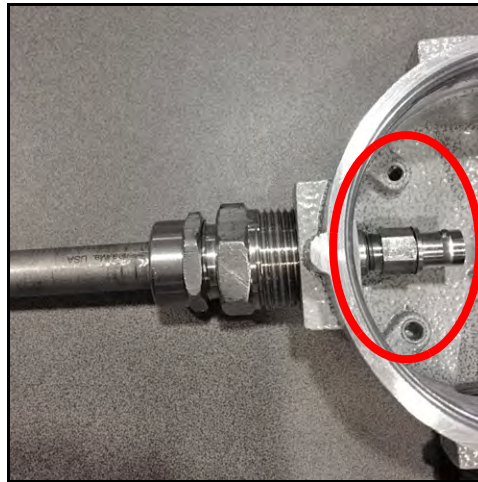

**Figure 8: Torquing Reducer into NPT Port**

3. If the BNC head extends too far into the junction box, it will make the assembly more difficult by reducing the amount of area available to properly store the excess cable. If the BNC head is not positioned approximately where it is pictured in the image above, loosen the compression fitting and adjust the transducer. Then, re-tighten the compression fitting after this is completed.
4. Torque the cable gland coming from the electronics main housing into the other 3/4" NPT port until there are at least five threads of engagement (see *Figure 9* below).



**Figure 9: Torquing the Cable Gland**



### 4.3 Connecting an XAMP (cont.)

With the transducer and the cable gland assembled, the junction box should now look like *Figure 10* below:



Figure 10: Assembled Transducer and Cable Gland

5. First, connect the right-angle male BNC plug to the exposed BNC cable from the cable gland assembly, as shown in *Figure 11* below.



Figure 11: Connecting BNC Plug to Cable



### 4.3 Connecting an XAMP (cont.)

6. Connect the female BNC plug of the XAMP to the male BNC transducer head, as shown in *Figure 12* below:



Figure 12: Female Plug to Male BNC Head

7. Wrap the extra length of cable around the perimeter of the junction box such that the BNC heads do not rest on other cables or on each other. An image of this is shown in *Figure 13* below.

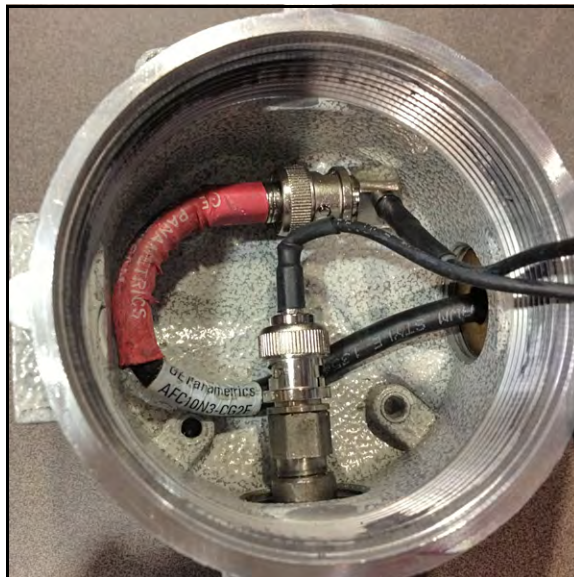

Figure 13: BNC Heads

### 4.3 Connecting an XAMP (cont.)

- Place the **XAMP** body into the junction box (see *Figure 14* below), resting the puck gently on the cables below it. Ensure that the cables of the **XAMP** rest naturally according to the slant at which they exit the epoxy, to reduce stress and strain on the joint. The **XAMP** should remain still, and the cap of the junction box should rotate freely around the **XAMP**.



Figure 14: Junction Box Cap

- Place the cover of the junction box over top of the **XAMP** and tighten the cover until the unit is closed and secure. Engage the set screw to discourage tampering or removal (see *Figure 15* below).

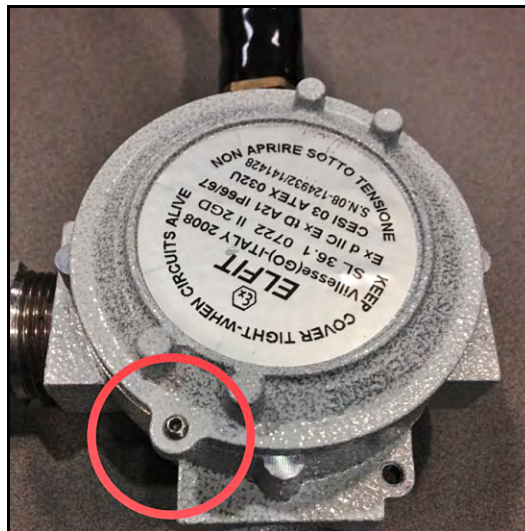

Figure 15: Set Screw of Junction Box

**Note:** To disconnect or uninstall the **XAMP** from the assembly, just reverse the procedures above.



[no content intended for this page]

## Chapter 5. Maintaining the T17 Transducers

### 5.1 Removing Transducers

After the transducers are properly installed into the pipe nozzles as described in *Chapter 4. “Inserting T17 Transducers into the Pipe”*, the T17 transducers require no additional adjustments.

Periodic inspection of the installation to verify the torque on the mounting bolts may be required, if erratic flow rate measurements are observed.

If you suspect something is wrong with a transducer or need to replace a transducer, use the removal procedure that follows.

#### 5.1.1 Using the Insertion Mechanism

Use the steps below to remove transducers that have been installed with the insertion mechanism:



**WARNING!** Follow all applicable safety codes while performing the following procedures.

1. Disconnect power from the flowmeter.



**WARNING!** Make sure the power is disconnected before performing the following steps.

2. Disconnect the transducer cables at the junction box.

### 5.1.1 Using the Insertion Mechanism (cont.)

3. On the insertion mechanism, remove the bolts that fasten the barrel flange to the packing gland flange.

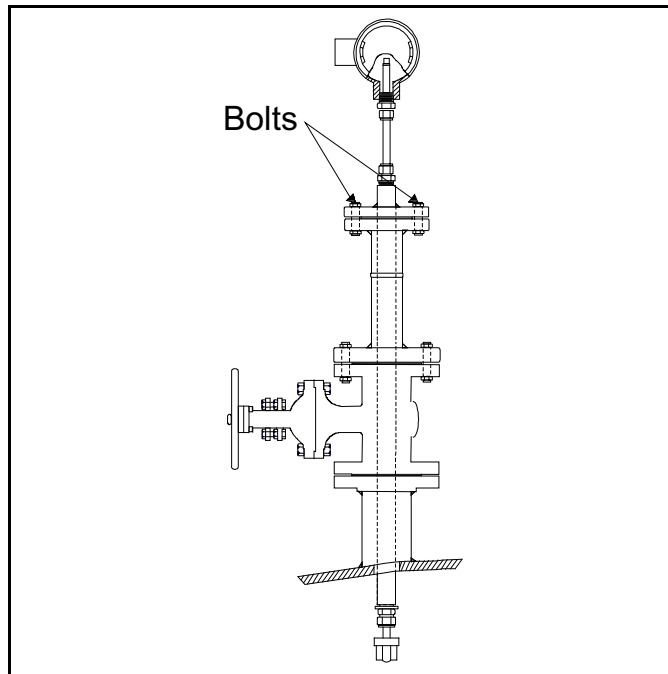

4. Retract the barrel from the packing gland until the transducer head is recessed in the packing gland. The stop ring will “click” when the transducer is fully recessed.

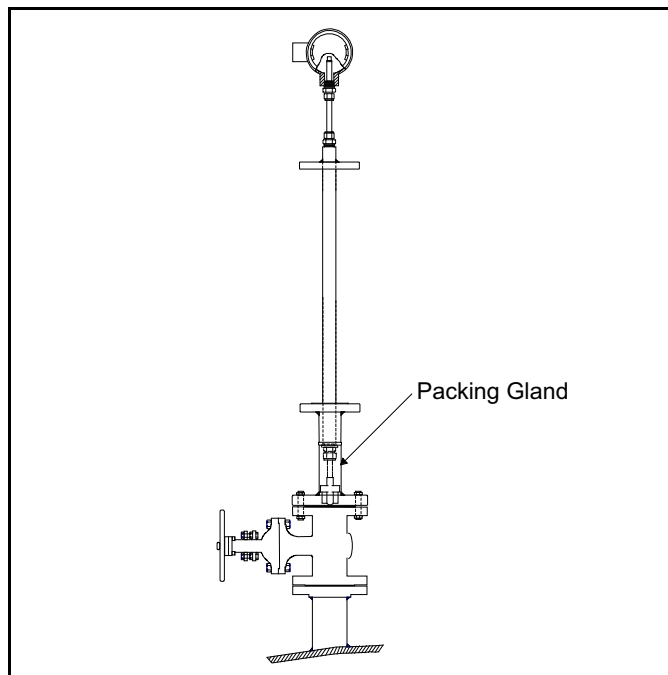

### 5.1.1 Using the Insertion Mechanism (cont.)

#### 5. CLOSE THE ISOLATION VALVE!



**WARNING!** Make sure the isolation valve is closed before performing the following steps.

6. After closing the isolation valve, remove the bolts that fasten the packing gland flange to the isolation valve flange, and lift the insertion mechanism by the barrel to remove it from the isolation valve.

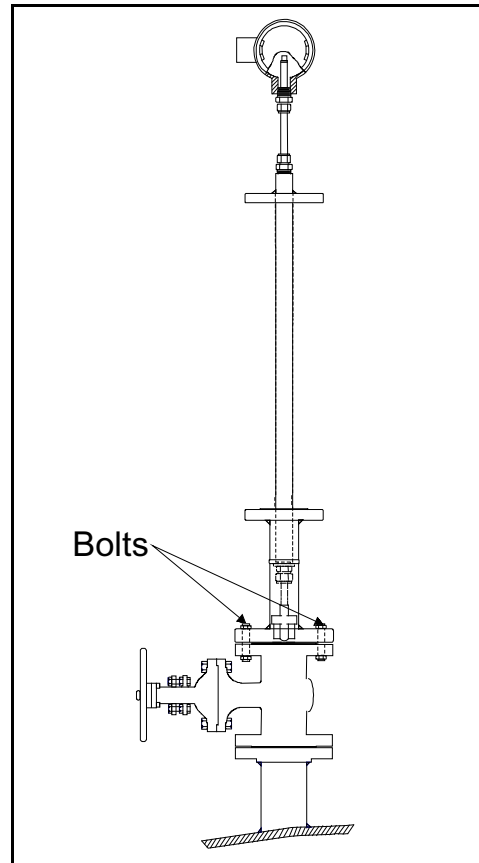

### 5.1.1 Using the Insertion Mechanism (cont.)

7. Install a new flange gasket on the isolation valve. Then, fasten a “*blind*” flange onto the isolation valve with the bolts removed in the previous step.

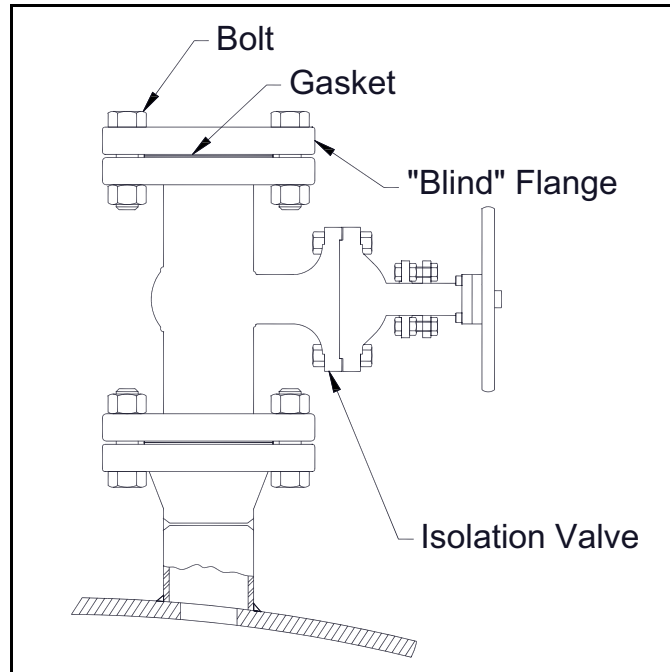

8. Disconnect the junction box on the end of the transducer by loosening the compression fitting.
9. Repeat steps 4 through 9 for the other transducer.





## Chapter 6. Specifications

### 6.1 T17 Transducer Physical Specifications

<b>Applications:</b>	Hazardous Area applications, Flare Gas, Hydrocarbon Gases using GE ultrasonic flow meter Models GF868 and XGF868i
<b>Installation Type:</b>	Wetted
<b>Materials of Construction:</b>	<i>Standard:</i> Titanium <i>Optional:</i> 316 Stainless Steel, Monel <sup>®</sup> or Hastelloy <sup>®</sup>
<b>Field Mounting:</b>	Flowcell, Hot or Cold Tap
<b>Process Connection:</b>	Flanged, 3 in. (80 mm)
<b>Holder Type:</b>	Insertion Mechanism
<b>Holder Ratings:</b>	150#, 300#
<b>Electrical Rating:</b>	200 V peak-to-peak, 5 mA
<b>Operating Temperature:</b>	-67° to +300°F (-55° to +150°C)
<b>Storage Temperature:</b>	-67° to +300°F (-55° to +150°C)
<b>Operating Pressure:</b>	12.7 to 1500 psia (87.6 to 10300 kPa)
<b>Operating Frequency:</b>	100 kHz

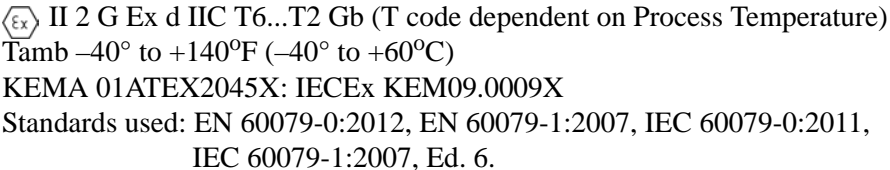
### 6.2 T17 Transducer Certifications

<b>North American - Explosion proof:</b>	 Class I, Division 1, Group C, D Class II, Class III, Division 1, Group E, F, G Single Seal
<b>European/International - Flameproof:</b>	 II 2 G Ex d IIC T6...T2 Gb (T code dependent on Process Temperature) Tamb -40° to +140°F (-40° to +60°C) KEMA 01ATEX2045X: IECEX KEM09.0009X Standards used: EN 60079-0:2012, EN 60079-1:2007, IEC 60079-0:2011, IEC 60079-1:2007, Ed. 6.
<b>North American - Weatherproof:</b>	 IP66, TYPE 4X 200Vpp, 5mA
<b>European/International - Weatherproof:</b>	 IP 66 CE

[no content intended for this page]

---

## Warranty

Each instrument manufactured by GE Sensing is warranted to be free from defects in material and workmanship. Liability under this warranty is limited to restoring the instrument to normal operation or replacing the instrument, at the sole discretion of GE Sensing. Fuses and batteries are specifically excluded from any liability. This warranty is effective from the date of delivery to the original purchaser. If GE Sensing determines that the equipment was defective, the warranty period is:

- one year from delivery for electronic or mechanical failures
- one year from delivery for sensor shelf life

If GE Sensing determines that the equipment was damaged by misuse, improper installation, the use of unauthorized replacement parts, or operating conditions outside the guidelines specified by GE Sensing, the repairs are not covered under this warranty.

---

**The warranties set forth herein are exclusive and are in lieu of all other warranties whether statutory, express or implied (including warranties or merchantability and fitness for a particular purpose, and warranties arising from course of dealing or usage or trade).**

---

## Return Policy

If a GE Sensing instrument malfunctions within the warranty period, the following procedure must be completed:

1. Notify GE Sensing, giving full details of the problem, and provide the model number and serial number of the instrument. If the nature of the problem indicates the need for factory service, GE Sensing will issue a RETURN AUTHORIZATION NUMBER (RAN), and shipping instructions for the return of the instrument to a service center will be provided.
2. If GE Sensing instructs you to send your instrument to a service center, it must be shipped prepaid to the authorized repair station indicated in the shipping instructions.
3. Upon receipt, GE Sensing will evaluate the instrument to determine the cause of the malfunction.

Then, one of the following courses of action will then be taken:

- If the damage is covered under the terms of the warranty, the instrument will be repaired at no cost to the owner and returned.
- If GE Sensing determines that the damage is not covered under the terms of the warranty, or if the warranty has expired, an estimate for the cost of the repairs at standard rates will be provided. Upon receipt of the owner's approval to proceed, the instrument will be repaired and returned.

[no content intended for this page]

We,

GE Sensing  
1100 Technology Park Drive  
Billerica, MA 01821  
USA

declare under our sole responsibility that the

**Models T3, T5, T8, T11, T14 and T17 Wetted Ultrasonic Flow Transducers  
Series BWT1 / F...PA / XAMP... Ultrasonic Flowmeter Transducer Assembly**

to which this declaration relates, are in conformity with the following standards:

- EN 60079-0: 2012
- EN 60079-1: 2007
- II 2 G Ex d IIC T6...615°C Gb **T3:** KEMA06ATEX0052, **T5:** KEMA01ATEX2045X, **T8:** KEMA02ATEX2283X, **T11:** KEMA02ATEX2252, **T14:** KEMA04ATEX2054X, **T17:** KEMA01ATEX2045X  
**Series BWT1 / F...PA / XAMP...:** KEMA01ATEX2051X; IEC Ex KEM09.0010X  
(DEKRA, Utrechtseweg, 310 Arnhem, The Netherlands - NoBo 0344)
- EN 61326-1: 2006, Class A, Table 2, Industrial Locations
- EN 61326-2-3: 2006
- EN 61010-1: 2012, Overvoltage Category II

Other standards used:

- EN 50014: 1997 + A1, A2
- EN 50018: 2000

following the provisions of the 2004/108/EC EMC and 94/9/EC ATEX Directives.

Where products were initially assessed for compliance with the Essential Health and Safety Requirements of the ATEX Directive 94/9/EC using earlier harmonized standards, a subsequent review has determined that "technical knowledge" is unaffected by the current harmonized standards listed above.

The units listed above and any ancillary equipment supplied with them do not bear CE marking for the Pressure Equipment Directive. They are supplied in accordance with Article 3, Section 3 (sound engineering practices and codes of good workmanship) of the Pressure Equipment Directive 97/23/EC for DN<25.

Billerica - January 2014

Issued



Mr. Gary Kozinski  
Certification & Standards, Lead Engineer



[no content intended for this page]



## Customer Support Centers

### U.S.A.

The Boston Center  
1100 Technology Park Drive  
Billerica, MA 01821  
U.S.A.  
Tel: 800 833 9438 (toll-free)  
978 437 1000  
E-mail: [sensing@ge.com](mailto:sensing@ge.com)

### Ireland

Sensing House  
Shannon Free Zone East  
Shannon, County Clare  
Ireland  
Tel: +353 61 61470200  
E-mail: [gesensingsnnservices@ge.com](mailto:gesensingsnnservices@ge.com)

An ISO 9001-2008 Certified Company  
[www.gemeasurement.com/quality-certifications](http://www.gemeasurement.com/quality-certifications)

[www.gemeasurement.com](http://www.gemeasurement.com)

©2015 General Electric Company. All rights reserved.  
Technical content subject to change without notice.